



Allen-Bradley

Remote I/O Adapter Module

Catalog Number 1747-ASB

User Manual

**Rockwell
Automation**

Important User Information

Because of the variety of uses for the products described in this publication, those responsible for the application and use of these products must satisfy themselves that all necessary steps have been taken to assure that each application and use meets all performance and safety requirements, including any applicable laws, regulations, codes and standards. In no event will Rockwell Automation be responsible or liable for indirect or consequential damage resulting from the use or application of these products.

Any illustrations, charts, sample programs, and layout examples shown in this publication are intended solely for purposes of example. Since there are many variables and requirements associated with any particular installation, Rockwell Automation does not assume responsibility or liability (to include intellectual property liability) for actual use based upon the examples shown in this publication.

Allen-Bradley publication SGI-1.1, *Safety Guidelines for the Application, Installation and Maintenance of Solid-State Control* (available from your local Rockwell Automation office), describes some important differences between solid-state equipment and electromechanical devices that should be taken into consideration when applying products such as those described in this publication.

Reproduction of the contents of this copyrighted publication, in whole or part, without written permission of Rockwell Automation, is prohibited.

Throughout this publication, notes may be used to make you aware of safety considerations. The following annotations and their accompanying statements help you to identify a potential hazard, avoid a potential hazard, and recognize the consequences of a potential hazard:

WARNING

Identifies information about practices or circumstances that can cause an explosion in a hazardous environment, which may lead to personal injury or death, property damage, or economic loss.

ATTENTION

Identifies information about practices or circumstances that can lead to personal injury or death, property damage, or economic loss.

IMPORTANT

Identifies information that is critical for successful application and understanding of the product.

Summary of Changes

The information below summarizes the changes to this manual since the last printing as Publication 1747-6.13 - December 1996.

To help you find new information and updated information in this release of the manual, we have included change bars as shown to the right of this paragraph.

New Information

For This New Information	See Page
Updated table of compatible scanners	1-9
Updated table of compatible RIO adapters	1-9
Updated list of compatible modules	1-10
Added primary/complementary chassis information for SW2	2-3
Clarified DIP SW setting	4-5
C-Tick certification	A-1

Preface	Who Should Use this Manual-	1
	Purpose of this Manual	1
	Contents of this Manual	1
	Related Documentation	2
	Terms and Abbreviations.	3
	Common Techniques Used in this Manual	5
	Rockwell Automation Support	6
	Your Questions or Comments on this Manual	6
	 Chapter 1	
Overview	1747-ASB Module Overview	1-1
	Remote I/O Overview	1-2
	How The Scanner Interacts With Adapters	1-2
	Scanner I/O Image Division	1-4
	Crossing Logical Rack Boundaries.	1-4
	Creating More Than One Logical Device by	
	Crossing a Logical Rack Boundary	1-5
	Transferring Data With RIO Discrete and Block Transfers	1-6
	RIO Discrete Transfer Example.	1-7
	Physical and Logical RIO Link Specifications	1-8
	Extended Node Capability	1-8
	Compatible RIO Scanners.	1-9
	Compatible RIO Adapters	1-9
	Compatible Modules	1-10
	1747-ASB Module Feature	1-10
	Hardware Features.	1-11
	Status Display and LEDs.	1-11
	DIP Switches	1-11
	RIO Link and Processor Restart Lockout Connector	1-13
	Door Label	1-13
	Self-Locking Tabs.	1-13
	Cable Tie Slots.	1-13
	 Chapter 2	
Quick Start for Experienced Users	Required Tools and Equipment	2-1
	Procedures	2-2
	SW1	2-3
	SW2	2-3
	SW3	2-3

Addressing

Chapter 3

Chassis Overview 3-1

Slot Numbering. 3-2

Addressing I/O Modules 3-2

 2-Slot Addressing 3-4

 2-Slot Addressing Considerations 3-5

 2-Slot Addressing Examples 3-6

 1-Slot Addressing 3-7

 1-Slot Addressing Considerations 3-8

 1-Slot Addressing Examples 3-9

 1/2-Slot Addressing 3-10

 1/2-Slot Addressing Considerations. 3-11

 1/2-Slot Addressing Examples. 3-12

How I/O Module Images Are Mapped 3-13

 How Discrete I/O Modules Are Mapped. 3-13

 How Specialty I/O Module Images Are Mapped 3-14

 When Block Transfer Mode is Selected. 3-14

 When Discrete Mode is Selected. 3-15

Configuration

Chapter 4

DIP Switch Information 4-1

 DIP Switch SW1. 4-2

 Logical Group Number (SW1-7,8). 4-4

 DIP Switch SW2. 4-4

 Primary/Complementary Chassis (SW2-3) 4-5

 Reserved (SW2-4) 4-9

Special Image and Chassis Size Considerations. 4-13

 Not Enough 1747-ASB Module Image to Map All of the Available Slots 4-13

 1747-ASB Image Size Exceeds Slot Requirements. 4-14

 One Slot of Pair is Present, and 1747-ASB Module Image is Available for Both Slots 4-14

 Both Slots Of A Pair Are Available But There Is Only Enough 1747-ASB Module Image Space Available For One Slot 4-15

 DIP Switch SW3. 4-15

 Processor Restart Lockout (SW3-2) 4-17

 Addressing Mode (SW3-5,6) 4-20

 Specialty I/O Mode (SW3-7). 4-21

 I/O Module Keying (SW3-8). 4-21

Switch Setting Summary 4-22

 SW2 4-22

 SW3 4-23

	Chapter 5	
Installation and Wiring	European Union Direct Compliance	5-1
	EMC Directive	5-1
	Installing the 1747-ASB Module	5-1
	Link Wiring	5-2
	Correct Link Wiring	5-3
	Incorrect Link Wiring	5-3
	Link Termination	5-4
	Wiring a Processor Restart Lockout Switch	5-5
	I/O Module Addressing Labels	5-6
	Using a PLC as a Master	5-6
	Using an SLC as a Master	5-6
	Octal Label Kit Installation	5-7
	Applying the Octal Filter Label	5-7
	Applying the Octal Door Label	5-7
Octal Kit and I/O Module Information	5-8	
	Chapter 6	
Start-Up and Operation	System Start-Up	6-1
	Powerup and Initialization Sequences	6-1
	Save Mode	6-2
	Check Mode	6-2
	Normal Operation	6-3
	Communication Exception	6-3
	Inhibit Condition	6-4
	Remote Expansion Chassis Power Loss	6-6
	Invalid RIO Link Transfers	6-6
	RIO Discrete or Block Transfers To Empty or Nonexistent Chassis Slots	6-6
	RIO Discrete Transfers To Block Transfer Chassis Slots	6-7
	RIO Block Transfers To Discrete Chassis Slots	6-7
	Invalid Length RIO Block Transfers	6-7
	Testing the 1747-ASB Module	6-7
	I/O Module Insertion into a Slot	6-9
	I/O Module Removal from a Scanned Slot	6-9
	I/O Module Removal from an Unscanned Slot	6-10
	Chapter 7	
Troubleshooting	Troubleshooting Introduction	7-1
	Contacting Rockwell Automation	7-2
	Status Operating Codes for Normal Operating Conditions	7-2
	Error Codes for Error Conditions	7-3
	DIP Switch Configuration Mismatch Fault Codes - Codes 1 and 2	7-5

I/O Module Configuration Mismatch
 Fault Codes - Code 3 7-7
 I/O Runtime Fault Codes - Code 4 7-8

Application Examples

Chapter 8

Basic SLC 500 Example Using and RIO Scanner 8-1
 RIO Device Configuration 8-2
 SLC Processor Image 8-3
 1747-ASB Module Configuration Details 8-4
 1747-ASB Module I/O Mapping Details 8-4
 RIO Address Label Examples 8-5
 Application Example Program 8-7
 Basic SLC 500 Example Using and RIO Scanner 8-7
 RIO Device Configuration 8-9
 SLC Processor Image 8-10
 1747-ASB Module 1 Configuration Details 8-10
 1747-ASB Module 2 Configuration Details 8-11
 1747-ASB Module 1 I/O Mapping Details 8-12
 1747-ASB Module 2 I/O Mapping Details 8-12
 RIO Address Label Examples 8-13
 Application Example Program 8-15
 PLC-5 Example 8-16
 RIO Device Configuration 8-17
 PLC Processor Image 8-18
 1747-ASB Module 1 Configuration Details 8-19
 1747-ASB Module 2 Configuration Details 8-20
 1747-ASB Module 1 I/O Mapping Details 8-21
 1747-ASB Module 2 I/O Mapping Details 8-22
 RIO Address Label Examples 8-23
 Application Example Program 8-24

Specifications

**Differences Between the
 1747-ASB Module and the
 1771-ASB Series C Module**

**DIP Switch and Address
 Configuration Worksheets
 Index**

Appendix A

Appendix B

Appendix C

Read this preface to familiarize yourself with the rest of the manual. This preface covers the following topics:

- who should use this manual
- the purpose of this manual
- terms and abbreviations
- conventions used in this manual
- Rockwell Automation support

Who Should Use this Manual-

Use this manual if you are responsible for designing, installing, programming, or troubleshooting control systems that use Allen-Bradley small logic controllers.

You should have a basic understanding of PLC[®] and SLC[®]500 products. You should understand programmable controllers and be able to interpret the ladder logic instructions required to control your application. If you do not, contact your local Allen-Bradley[®] representative for information on available training courses before using this product.

Purpose of this Manual

This manual is a learning and reference guide for the remote I/O adapter module. It describes the procedures you use to address, configure, install, and operate the 1747-ASB remote I/O adapter module.

Contents of this Manual

Chapter	Title	Contents
	Preface	Describes the purpose, background, and scope of this manual. Also specifies the audience for whom this manual is intended.
1	Overview	Explains and illustrates the theory behind the 1747-ASB module's operation. Covers hardware and software features, compatible devices, and setup.
2	Quick Start for Experienced Users	Serves as a Quick Start Guide for the 1747-ASB module.
3	Addressing	Gives a chassis overview, and explains slot numbering, I/O module image mapping, 2-slot, 1-slot, and 1/2-slot addressing.

4	Configuration	Contains DIP switch information, and shows odd size chassis and image conditions.
5	Installation and Wiring	Provides installation procedures and wiring guidelines.
6	Start-up and Operation	Explains powerup and initialization sequences, normal operation, communication exceptions, remote expansion power loss, invalid RIO link transfers, and testing the 1747-ASB module.
7	Troubleshooting	Shows how to interpret and correct problems with your 1747-ASB module.
8	Application Examples	Examines both SLC 500 and PLC-5/40t applications using a 1747-ASB module. Gives examples of the ladder programming necessary to achieve the described result.
Appendix A	Specifications	Contains 1747-ASB and RIO link specifications, as well as throughput information.
Appendix B	Differences Between the 1747-ASB and 1771-ASB Series C Modules	Provides a point-by-point comparison of the 1747 and 1771 ASB modules.
Appendix C	Worksheets	Contains worksheets for setting the 1747-ASB module's DIP switches and addressing remote I/O modules with an SLC processor.

Related Documentation

The following documents contain additional information concerning Allen-Bradley SLC and PLC products. To obtain a copy, contact your local Allen-Bradley office or distributor.

For	Read This Document	Document Number
An overview of the SLC 500 family of products	SLC 500 System Overview	1747-SO001
A description on how to install and use your Modular SLC 500 programmable controller	Installation & Operation Manual for Modular Hardware Style Programmable Controllers User Manual	1747-UM011
Information regarding the use of a 1747-KE module as a communications interface	DH-485/RS-232C Interface Module User Manual	1747-6.12
Information regarding the use of the 1747-DCM as a remote I/O device	Direct Communication Module User Manual	1747-6.8

Information regarding the use of the 1747-SN SLC RIO scanner	RIO Scanner User Manual	1747-6.6
Information regarding the use of analog modules with the SLC 500 system	SLC 500 Analog I/O Modules User Manual	1746-6.4
Information regarding programming your BASIC module	SLC 500 BASIC Language Reference	1746-RM001
In-depth information on grounding and wiring Allen-Bradley programmable controllers	Allen-Bradley Programmable Controller Grounding and Wiring Guidelines	1770-4.1
A description on how to install a PLC-5r system	PLC-5 Family Programmable Controllers Hardware Installation Manual	1785-6.6.1
A description of important differences between solid-state programmable controller products and hard-wired electromechanical devices	Application Considerations for Solid-State Controls	SIG-1.1
An article on wire sizes and types for grounding electrical equipment	National Electrical Code	Published by the National Fire Protection Association of Boston, MA.
A glossary of industrial automation terms and abbreviations	Allen-Bradley Industrial Automation Glossary	AG-7.1

The following terms and abbreviations are specific to this product. For a complete listing of Allen-Bradley terminology, refer to the *Allen-Bradley Industrial Automation Glossary*, Publication Number AG-7.1.

Terms and Abbreviations

Adapter - Any physical device that is a slave on the RIO link.

Adapter Image - That portion of the scanner image assigned to an individual adapter. You configure the adapter image by assigning it a starting logical rack number, starting logical group number and the number of logical groups it uses. In the case of the 1747-ASB module, this is referred to as the 1747-ASB module image.

ASB Module - The Catalog Number 1747-ASB Remote I/O Adapter Module. The 1747-ASB module is an adapter.

ASB Module Chassis - The chassis directly controlled by the 1747-ASB module. This includes the remote chassis and (if installed) two remote expansion chassis.

Discrete I/O Module - An I/O module used to sense or control two-state (ON/OFF) devices.

Inhibit - A function by which the scanner stops communicating with a logical device. The logical device will consider itself inhibited if it

does not receive communications from the scanner within a certain period of time.

I/O Module - Any 1746 or 1747 I/O module that is supported by the 1747-ASB module.

Local Expansion Chassis - A chassis that is connected to a local SLC chassis using a 1747-C9 (91.4 cm [36 in.]) or 1747-C7 (15.2 cm [6 in.]) cable.

Local PLC Chassis - The 1771 chassis that contains a PLC processor and scanner.

Local SLC Chassis - The chassis that contains the SLC processor and scanner.

Logical Device - Any portion of a logical rack that is assigned to a single adapter. Adapters may appear as more than one logical device.

Logical Group - A logical group consists of one input and one output word within a logical rack. A word consists of 16 bits, each bit represents one terminal on a discrete I/O module.

Logical Rack - A fixed section of the scanner image comprised of eight input words and eight output words.

Logical Slot - A logical slot consists of one input and one output byte within a logical group. A byte consists of 8 bits, each bit represents one terminal on a discrete I/O module.

PLC Chassis - A physical PLC rack that houses 1771 I/O modules and PLC processors.

Remote Chassis - The chassis containing a 1747-ASB module and connected to the local SLC or PLC chassis via the RIO link.

Remote Expansion Chassis - A chassis that is connected to a remote chassis using a 1747-C9 (91.4 cm [36 in.]) or 1747-C7 (15.2 cm [6 in.]) cable.

Reset, Adapter Decide - Commands sent by the scanner to a logical device during an RIO discrete transfer. These commands instruct the logical device to reset all of its discrete outputs if hold last state is not selected, or to hold all of its discrete outputs in their last state if hold last state is selected.

Reset, Adapter Reset - Commands sent by the scanner to a logical device during an RIO discrete transfer. These commands instruct the logical device to reset all of its discrete outputs regardless of the hold last state selection.

RIO Block Transfer - The exchange of up to 64 words of data between the scanner and adapter. RIO block transfers only occur if you program them in your processor control program. The 1747-ASB module supports a block transfer of up to 8 words.

RIO Discrete Transfer - The exchange of image data between the scanner and adapter. RIO discrete transfers occur continuously whenever the scanner and adapter are communicating on the RIO link.

RIO Link - An Allen-Bradley communication system supporting high-speed serial transfer of Remote I/O (RIO) control information. This link consists of one master one or more slaves.

Scanner - The communication master on the RIO link.

Scanner Image - The data table area within the scanner, used to exchange I/O information between the scanner and all the adapters on the RIO link. The scanner image is a portion of the SLC or PLC processor image.

SLC Chassis - A physical SLC rack that houses SLC processors, 1746 and 1747 I/O modules.

Slot - The physical location in any chassis used to insert I/O modules.

Specialty I/O Module - An I/O module other than a discrete I/O module (e.g., an analog module).

The following conventions are used throughout this manual:

Common Techniques Used in this Manual

- Bulleted lists such as this one provide information, not procedural steps.
- Numbered lists provide sequential steps or hierarchical information.
- *Italic* type is used for emphasis.
- Text in `this font` indicates words or phrases you should type.

Allen-Bradley offers support services worldwide, with over 75 Sales/Support Offices, 512 authorized Distributors and 260 authorized Systems Integrators located throughout the United States alone, plus Allen-Bradley representatives in every major country in the world.

Rockwell Automation Support

Before you contact Rockwell Automation for technical assistance, we suggest you please review the troubleshooting information contained in this publication first.

If the problem persists, call your local Rockwell Automation representative or contact Rockwell Automation in one of the following ways:

Phone	United States/Canada	1.440.646.5800
	Outside United States/Canada	You can access the phone number for your country via the Internet: <ol style="list-style-type: none"> 1. Go to http://www.ab.com 2. Click on <i>Product Support</i> (http://support.automation.rockwell.com) 3. Under <i>Support Centers</i>, click on <i>Contact Information</i>
Internet	⇒	<ol style="list-style-type: none"> 1. Go to http://www.ab.com 2. Click on <i>Product Support</i> (http://support.automation.rockwell.com)

Your Questions or Comments on this Manual

If you find a problem with this manual, please notify us of it.

If you have any suggestions for how this manual could be made more useful to you, please contact us at the address below:

Rockwell Automation
Automation Control & Information Group
Technical Communication, Dept. 602V
P.O. Box 2086
Milwaukee, WI 53201-208

Overview

This chapter presents:

- 1747-ASB module overview
- remote I/O overview
- compatible devices
- 1747-ASB module features
- setup and operational overview

1747-ASB Module Overview

The 1747-ASB module is an SLC 500 single-slot, RIO communication link module. It occupies the first slot (slot 0) of a 1746 remote chassis, where the SLC processor normally resides.

The 1747-ASB module is an adapter, or slave, on the RIO link, and the master of the remote chassis and remote expansion chassis it is installed in. *Remote expansion chassis are optional.* It acts as a gateway between the scanner and the I/O modules residing in the remote chassis and remote expansion chassis. The 1747-ASB module maps the image of the I/O modules in its remote chassis and remote expansion chassis directly to the SLC or PLC processor image.

Output data is sent from the scanner of either the SLC *or* PLC local chassis to the 1747-ASB module across the RIO link. This data is automatically transferred to the output modules across the chassis backplane by the 1747-ASB module. Inputs from the input modules are collected via the backplane by the 1747-ASB module and sent back to the scanner across the RIO link. No user programming of the 1747-ASB module is necessary.

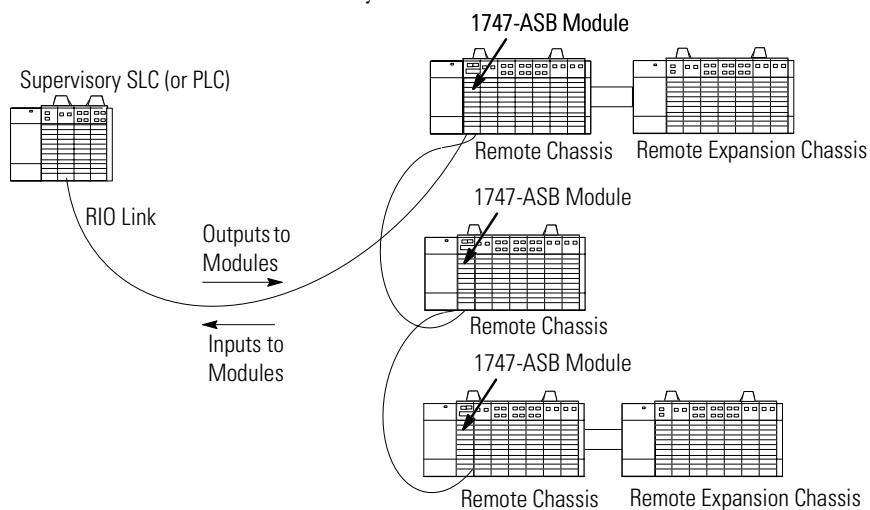

To better understand the use of the 1747-ASB module, you should have an understanding of the RIO link. The RIO link is an Allen-Bradley communications system supporting high-speed transfer of control information. An RIO link consists of a single master device and one or more slave devices. The master device is referred to as the scanner. The slave devices are referred to as adapters (such as the 1747-ASB module).

Remote I/O Overview

RIO scanners and adapters work together to serially communicate PLC or SLC processor data to remotely located I/O devices. PLC and SLC processors exchange inputs and outputs with scanners. Scanners exchange inputs and outputs with adapters located on the RIO link. The adapter's control is based on the adapter type.

How The Scanner Interacts With Adapters

The scanner's function is to continuously scan the adapters on the RIO link in a consecutive manner. The scan consists of one or more RIO discrete transfers to each adapter on the RIO link.

RIO discrete transfers consist of the scanner sending output image data and communication commands to the adapter that instruct the adapter on how to control its output. (These include run, reset, adapter reset, and reset decide commands.) The adapter responds by sending input data to the scanner. The scanner performs as many RIO discrete transfers as necessary to update the entire adapter image. If RIO discrete transfers do not occur, data is not exchanged between the scanner and adapter.

IMPORTANT

RIO discrete transfers are asynchronous with the processor scan.

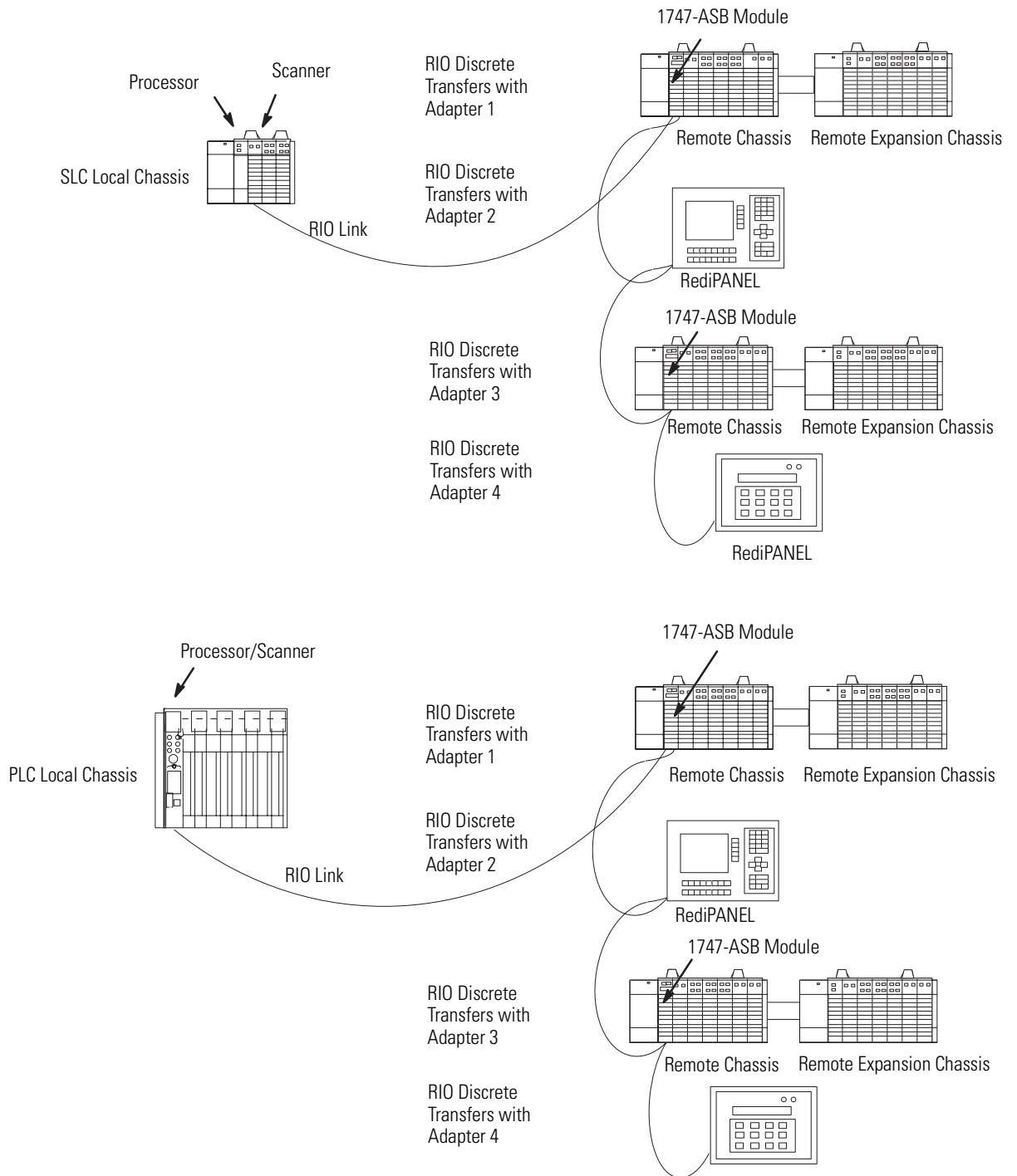

Scanner I/O Image Division

The scanner allows each adapter to use a fixed amount (user defined) of the scanner's input and output image. Part of the processor's image is used by local I/O, the other portion is used by the scanner for remote I/O. For a PLC-5, logical rack 0 is dedicated for local I/O.

The scanner's remote I/O image is divided into logical racks and further divided into logical groups. A full logical rack consists of eight input and eight output image words. A logical group consists of one input and one output word in a logical rack. Each logical group is assigned a number from 0 to 7. The number of racks available for remote I/O depends on the scanner you are using.

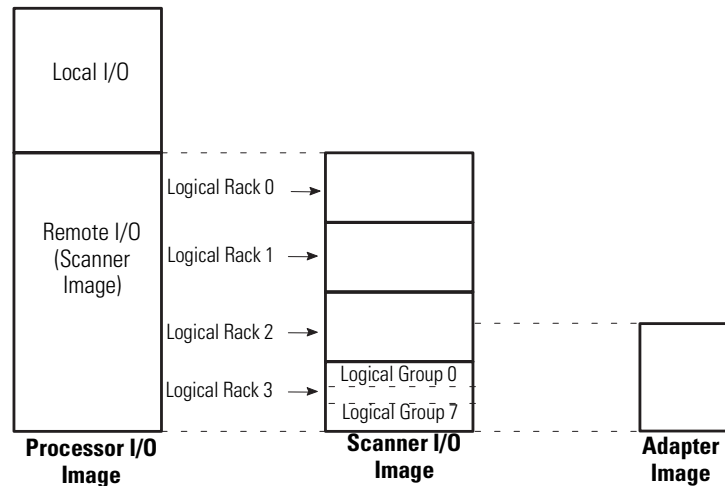

The scanner image also contains the image of each adapter on the RIO link. The adapter is assigned a portion of the scanner image, which is referred to as the adapter image.

Crossing Logical Rack Boundaries

Adapter image size is expressed in an even number of groups. For example, the 1747-ASB module image can be any size between 2 logical groups and 32 logical groups (4 logical racks), in 2 logical group increments.

If the adapter's image size is greater than 8 logical groups, the image crosses logical rack boundaries. If an adapter's image size is less than 8 logical groups, it too can cross a logical rack boundary depending upon the starting logical group number. The significance of crossing logical rack boundaries is discussed in the next section.

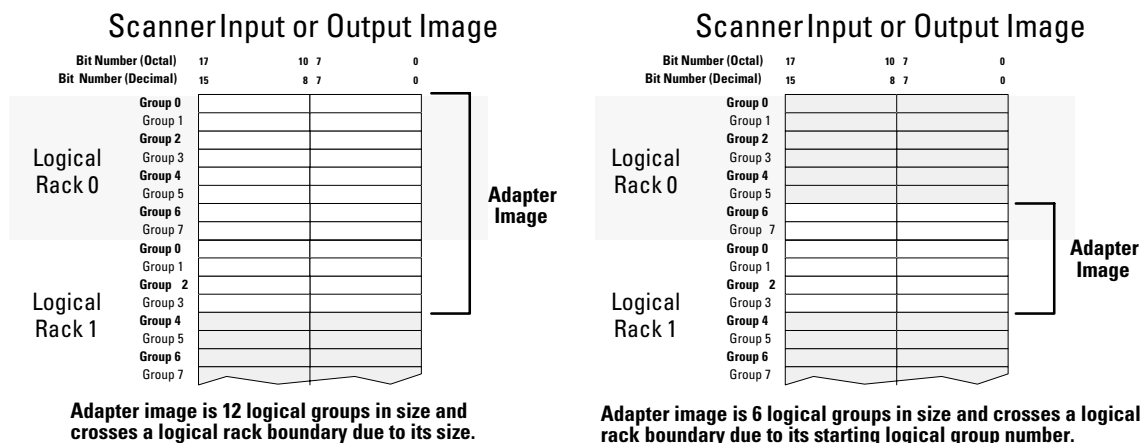

IMPORTANT

Due to SLC and PLC addressing differences, when the 1747-ASB module is used with an SLC processor, the image bit numbers are 0 to 7, 8 to 15 decimal. When the 1747-ASB module is used with a PLC processor, the image bit numbers are 0 to 7, 10 to 17 octal. The I/O image figures, like the two above, indicate the type of image bit numbers used (octal, decimal, or both) throughout this manual.

Creating More Than One Logical Device by Crossing a Logical Rack Boundary

RIO discrete transfers occur on a logical device basis, not an adapter basis. A logical device is any portion of a logical rack that is assigned to a single adapter.

When an adapter's image is more than one logical device, the scanner sees the single adapter as multiple adapters on the RIO link. The scanner communicates with each logical device independently, even if the logical devices are all assigned to one adapter. If an adapter image is more than one logical device, the following is true:

Not all of the adapter image is updated by the scanner at the same time. The number of logical devices determines the number of RIO discrete transfers that are needed to update the entire adapter image.

The adapter may receive different communication commands for each logical device. In this case, the adapter decides which command it responds to.

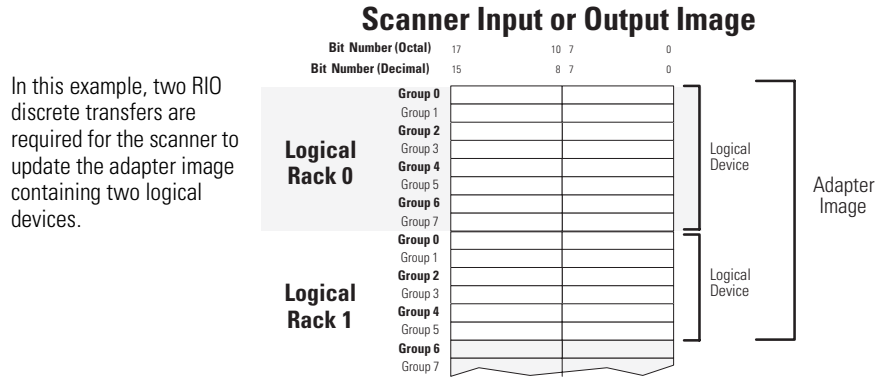

To understand how an adapter's logical devices are assigned, use appendix D to determine the address configuration of your remote I/O modules. You may then want to reassign certain adapters so their images do not cross logical rack boundaries, allowing the scanner to update their images in one RIO discrete transfer.

IMPORTANT

The 1747-ASB module always functions as one adapter on the RIO link, even though it may contain more than one logical device. For example, the 1747-ASB module does not begin normal operation until all of its logical devices are receiving RIO discrete transfers from the scanner.

Transferring Data With RIO Discrete and Block Transfers

Input and output image data and command information is quickly exchanged between a scanner and adapter using RIO discrete transfers. RIO discrete transfers are the simplest way a scanner and adapter communicate with each other. RIO discrete transfers, which are transparent to the user, consist of the scanner sending the output image data to the adapter, and the adapter transmitting input data to the scanner. Each RIO discrete transfer also contains scanner commands for the adapter.

RIO block transfers are initiated by a special command from the PLC processor, typically when large amounts of data must be exchanged with one specialty I/O module. Block transfers use the basic RIO discrete transfer mechanism of the RIO link. However, the actual transfer of data occurs asynchronous to the discrete transfers. It is possible for several discrete transfers to occur before a block transfer is processed.

RIO Discrete Transfer Example

This example illustrates how additional discrete transfers are required when an adapter image crosses logical rack boundaries. It consists of one scanner and three adapters. Adapter 1 requires one RIO discrete transfer from the scanner to update its entire image. Adapter 2 requires two RIO discrete transfers to update its image. Adapter 3 requires three RIO discrete transfers to update its image.

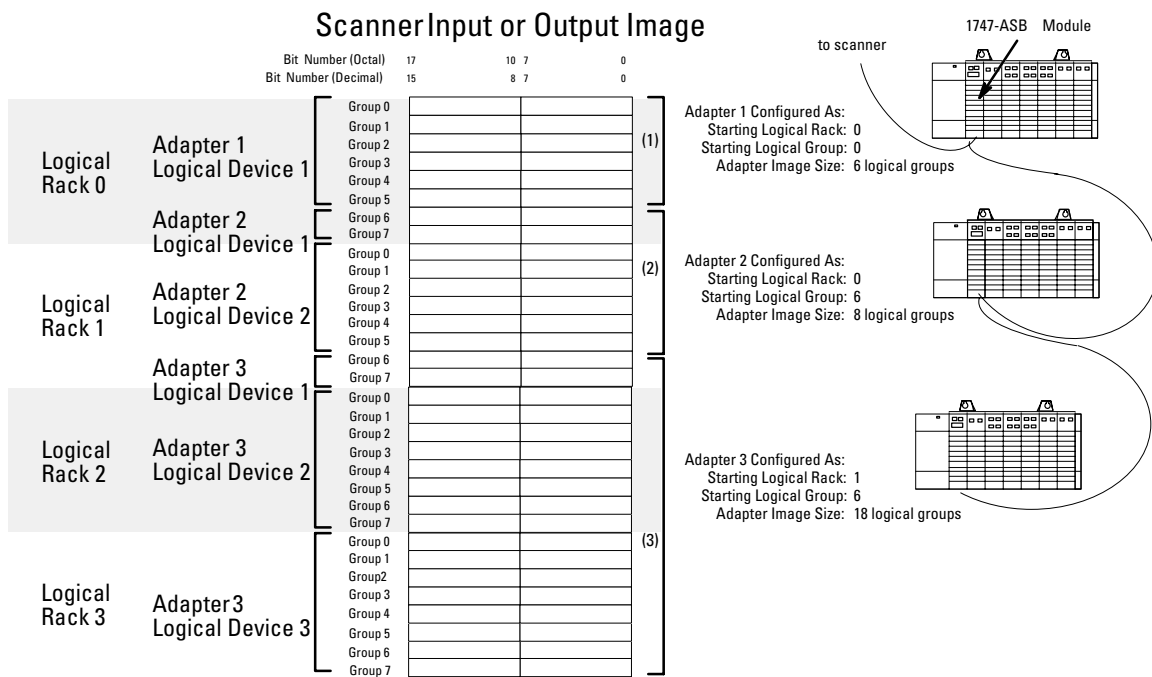

- (1) The scanner updates the adapter image in one RIO discrete transfer because the adapter image is contained within one logical rack.
- (2) The scanner updates the adapter image in two RIO discrete transfers because the adapter image crosses a logical rack boundary making the adapter image appear as two logical devices.
- (3) The scanner updates the adapter image in three RIO discrete transfers because the adapter image crosses two logical rack boundaries making the adapter image appear as three logical devices.

Physical and Logical RIO Link Specifications

The maximum number of adapters that your scanner can communicate with is determined by the scanner and adapter's physical and logical specifications, as described below:

Physical Specifications are the maximum number of adapters that can be connected to the scanner. For more information, see Extended Node Capability below.

Logical Specifications for the scanner are the maximum number of logical racks the scanner can address, how the logical racks can be assigned, and whether the scanner can perform block transfers.

For adapters, logical specification refers to the maximum size of the adapter's RIO image.

Extended Node Capability

Both scanners and adapters can have extended node capability. Extended node capability allows you to use an 82 Ohm termination resistor at both ends of the RIO link for all baud rates. Extended node capability also allows for up to 32 adapters to be placed on the RIO link.

Extended node capability can only be used if the scanner and *all* adapters on the RIO link have extended node capability. *The 1747-ASB module has extended node capability.*

The tables on pages 1-10 and 1-11 provide lists of compatible RIO scanners and adapters.

The 1747-ASB module is compatible with all Allen-Bradley scanners. Scanners that do not support RIO block transfers do not work with all of the I/O modules supported by the 1747-ASB module. For example, the Catalog Number 1747-SN Series A, RIO Scanner does not work with a Catalog Number 1746-BAS, BASIC module because the scanner does not support RIO block transfer.

Compatible RIO Scanners

Refer to the appropriate scanner manual for details concerning physical and logical specifications.

Catalog Number	Description
1771-SN ⁽¹⁾	Sub I/O scanner for Mini-PLC [®] -2 and PLC-5 families
1785-L11B ⁽²⁾	PLC-5/11™ (in scanner mode)
1785-L20B ⁽²⁾	PLC-5/20™ (in scanner mode)
1785-L30x ⁽²⁾	PLC-5/30™ (in scanner mode)
1785-L40x ⁽²⁾	PLC-5/40 (in scanner mode)
1785-L60x ⁽²⁾	PLC-5/60™ (in scanner mode)
1747-SN ⁽²⁾⁽³⁾	SLC Remote I/O Scanner

(1) Revision D or later.

(2) Extended node capability.

(3) Series A scanner does not have block transfer.

Compatible RIO Adapters

The 1747-ASB module can physically reside on the RIO link with any other adapter. The following table lists the adapters available for use with an RIO link.

Catalog Number	Description
1785-L30x ⁽¹⁾⁽²⁾	PLC-5/30 (in adapter mode)
1785-L40x ⁽¹⁾⁽²⁾	PLC-5/40 (in adapter mode)
1785-L60x ⁽¹⁾⁽²⁾	PLC-5/60 (in adapter mode)
1771-ASC	Remote I/O Adapter Module
1771-ASB ⁽³⁾⁽⁴⁾	Remote I/O Adapter Module
1771-RIO	Remote I/O Interface Module
1771-DCM	Direct Communication Module
1747-DCM ⁽¹⁾	Direct Communication Module
2711-xx ⁽¹⁾	PanelView™ Terminal
1336-G2 ⁽¹⁾	Remote I/O Adapter for 1336 AC Industrial Drives
1395-NA ⁽¹⁾	Remote I/O Adapter for 1395 DC Industrial Drives
1747-ASB ⁽¹⁾	Remote I/O Adapter Module

(1) Extended node capability.

(2) In adapter mode.

(3) Series A, B, and C.

(4) Extended node capability for Series B and C.

Compatible Modules

The 1747-ASB module supports all SLC 5/01 compatible I/O modules (class 0 and 1). The following modules can be placed in the remote chassis and remote expansion chassis:

- all discrete I/O modules
- all analog I/O modules
- BASIC Modules, Catalog Number 1746-BAS, -BAST (SLC 5/01 mode)
- IMC 110 motion control module, Catalog Number 1746-HS
- Direct Communication Module, Catalog Number 1747-DCM
- Thermocouple/mV input modules, Catalog Number 1746-NT4, NT8
- RTD/Resistance Modules, Catalog Number 1746-NR4, NR8
- High Speed Counter Module, Catalog Number 1746-HSCE 2

1747-ASB Module Feature

The 1747-ASB module has the following features:

- communicates I/O data up to a maximum of 3040 meters (10,000 feet)
- supports 57.6K, 115.2K, and 230.4K baud operation on the RIO link
- supports any mix of 1746 discrete or analog I/O
- controls up to 30 slots using remote expansion chassis
- allows use of 2-slot, 1-slot, and 1/2-slot addressing
- allows for image sizes between 2 and 32 logical groups (user selectable)
- incorporates enhanced operating status and troubleshooting capability using three 7-segment displays
- provides non-volatile memory for convenient I/O module slot keying
- provides discrete output module hold last state selection
- provides RIO link processor restart lockout selection
- incorporates extended node capability
- supports RIO block transfers and RIO discrete transfers for analog and other specialty I/O modules
- supports complementary I/O on the RIO link

Hardware Features

The 1747-ASB module's hardware features are highlighted below. Detailed installation, operation, and troubleshooting information is contained in chapters 5, 6, and 7.

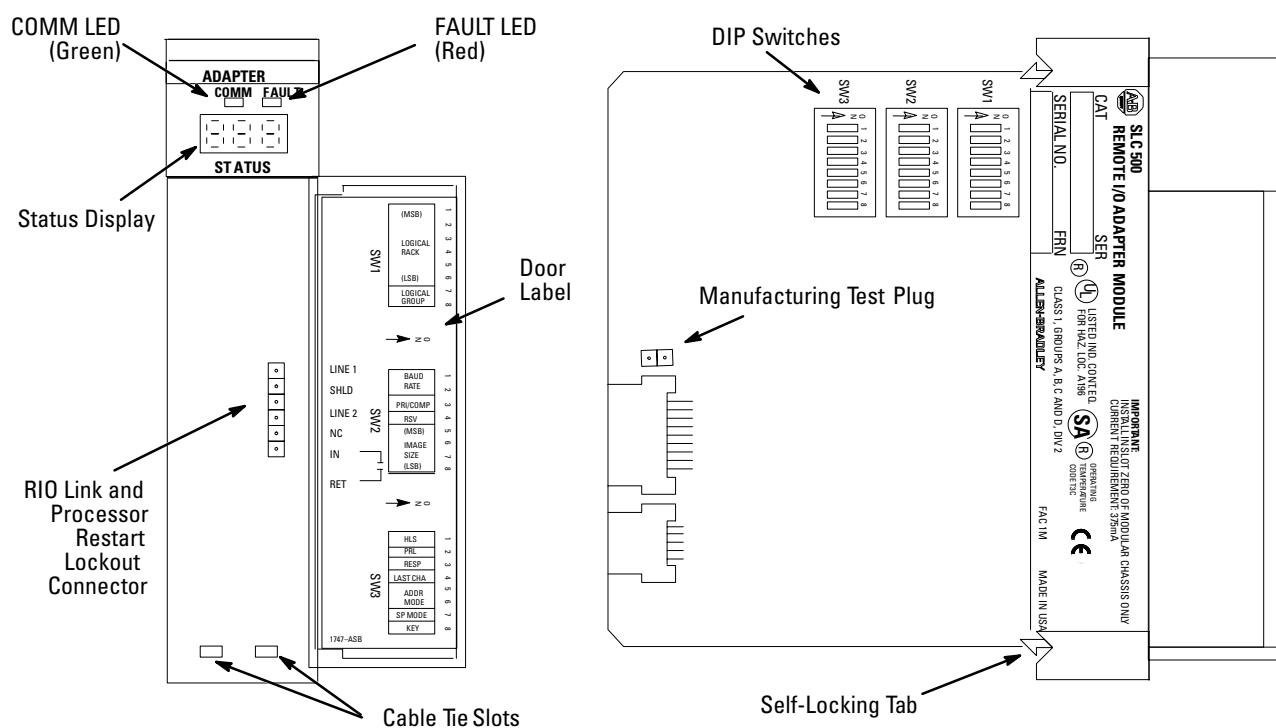

Status Display and LEDs

The Status Display provides alphanumeric status of the 1747-ASB module and RIO link. When combined with the COMM and FAULT LEDs, they are very effective troubleshooting tools.

DIP Switches

The 1747-ASB module's three DIP switches allow you to configure the following items:

- **Starting Logical Rack Number (Logical Rack)** - is the 1747-ASB module's starting logical rack number in the scanner's image.
- **Starting Logical Group Number (Logical Group)** - is the 1747-ASB module's starting logical group number within the scanner's image.

- **Baud Rate (Baud Rate)** - is the 1747-ASB module's RIO link communication rate. The baud rate must be the same for all adapters on the RIO link.
- **Primary/Complementary SLC Chassis (PRI/COMP)** - determines whether the 1747-ASB module appears to the scanner as a primary or complementary chassis.
- **Adapter Image Size (IMAGE SIZE)** - indicates the I/O image size to be reserved for the adapter. It can be any size between 2 and 32 groups in two logical group increments.
- **Hold Last State (HLS)** - determines whether the discrete output modules are held in their last state when:
 - RIO link communication with the 1747-ASB module is lost.
 - The scanner inhibits the 1747-ASB module.
 - The scanner sends Reset, Adapter Decide commands to the 1747-ASB module.
- **Processor Restart Lockout (PRL)** - determines whether the 1747-ASB module automatically resumes RIO link communications if communication is lost and then restored.
- **Link Response Time (RESP)** - selects restricted or unrestricted RIO link response time.
- **Last Chassis (LAST CHA)** - When the 1747-ASB module is used with a PLC-2 or PLC-5, this switch indicates to the scanner that the 1747-ASB module is the last adapter mapped into the 1747-ASB module's highest logical rack.
- **Addressing Mode (ADDR MODE)** - determines the 1747-ASB module's remote chassis and remote expansion chassis addressing mode. 2-slot, 1-slot, and 1/2-slot is available.
- **Specialty I/O Mode (SP MODE)** - determines whether the 1747-ASB module discretely maps or block transfer maps specialty I/O modules in its remote chassis and remote expansion chassis.
- **I/O Module Keying (KEY)** - determines if the 1747-ASB module saves its current I/O module and DIP switch configuration to its non-volatile memory, or if the 1747-ASB module compares the current I/O module and DIP switch configuration to the one saved in its non-volatile memory.

RIO Link and Processor Restart Lockout Connector

The 6-pin male connector attaches the 1747-ASB module to the RIO link and processor restart lockout device.

Door Label

The door label provides DIP switch and wiring information.

Self-Locking Tabs

Self-locking tabs secure the module in the rack. No tools are necessary to install or remove a module.

Cable Tie Slots

Cable tie slots can be used to secure the wiring cable to the module.

Quick Start for Experienced Users

This chapter helps you to get started using the 1747-ASB module. We base the procedures here on the assumption that you have an understanding of PLC and SLC 500 products, as well as the RIO link. You should understand electronic process control and be able to interpret the ladder logic instructions required to generate the electronic signals that control your application.

Because it is a start-up guide for experienced users, this chapter *does not* contain detailed explanations about the procedures listed. It does, however, reference other chapters in this book where you can get more detailed information.

If you have any questions, or are unfamiliar with the terms used or concepts presented in the procedural steps, *always read the referenced chapters* before trying to apply the information.

This chapter:

- tells you what tools and equipment you need
- lists preliminary considerations
- describes when to address and configure the module
- explains how to install and wire the module
- discusses system power-up procedures

Have the following tools and equipment ready:

Required Tools and Equipment

- medium blade screwdriver
- (2) 1/2 watt terminating resistors (See chapter 5, Installation and Wiring, for correct size.)
- an adequate length of RIO communication cable (Belden 9463) for your specific application (See Chapter 5 Installation and Wiring, for maximum cable distances.)

Procedures

1.	Check the contents of shipping box.	Reference
<p>Unpack the shipping box making sure that the contents include:</p> <ul style="list-style-type: none"> • Remote I/O adapter module (Catalog Number 1747-ASB) • user manual (Publication 1747-6.13) <p>If the contents are incomplete, call your local Rockwell Automation representative for assistance.</p>		-
2.	Ensure your chassis supports placement of the 1747-ASB module.	Reference
<p>Check to see that your chassis supports placement of the adapter module by:</p> <ul style="list-style-type: none"> • reviewing the power requirements of your system (The adapter consumes 600 mA at 5VDC.) • calculating the total load on the system power supply using the procedure described in Appendix B 		<p>Appendix A (Specifications)</p> <p>Appendix B (Understanding your SLC 500/1746 Control System)</p>
3.	Choose the type of slot addressing you will use.	Reference
<p>Select 1747-ASB addressing (i.e., 2-slot, 1-slot, or 1/2-slot). A configuration worksheet is included in appendix D to assist you in 1747-ASB image table addressing.</p> <p>Important: Due to SLC and PLC addressing differences, when the 1747-ASB module is used with an SLC processor, the image bit numbers are 0 to 7, 8 to 15 decimal. When the 1747-ASB module is used with a PLC processor, the image bit numbers are 0 to 7, 10 to 17 octal.</p>		<p>Chapter 3 (Addressing)</p> <p>Appendix D (DIP Switch and Address Configuration Worksheets)</p>
4.	Configure the module using the DIP switches.	Reference
<p>Set the DIP switches (located on the printed circuit board) to the desired setting. A worksheet is included in appendix D to assist you in DIP switch configuration.</p>		<p>Chapter 4 (Configuration)</p> <p>Appendix D (DIP Switch and Address Configuration Worksheets)</p>

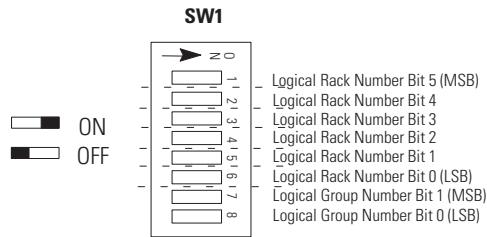

SW1

Logical Rack Number
For details, see page 4-2.
Logical Group Number

7	8	Group
ON	ON	0 (default)
ON	OFF	2
OFF	ON	4
OFF	OFF	6

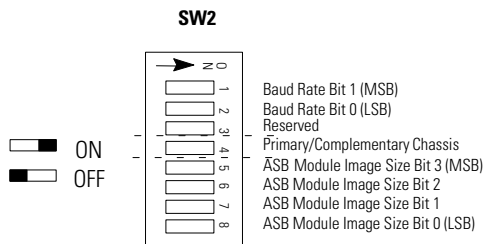

SW2

Baud Rate

1	2	Baud Rate
ON	ON	57.6K (default)
ON	OFF	115.2K
OFF	ON	230.4K
OFF	OFF	INVALID

- Primary/Complementary Chassis
ON=Primary
OFF=Complementary (Default)
- 1747-ASB Module Image Size
For details, see page 4-9.

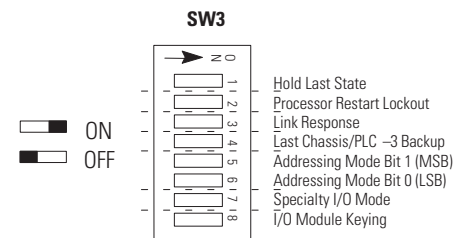

SW3

- Hold Last State
ON=Hold Last State
OFF = Do Not Hold Last State (default)
- Processor Restart Lockout
ON = Automatic Restart (default)
OFF = Processor Lockout
- Link Response
ON = Restricted 9 (default)
OFF = Unrestricted
- Last Chassis
ON = Not Last Chassis (default)
OFF = Last Chassis
- Addressing Mode

5	6	Address
ON	ON	Invalid
ON	OFF	1-slot Addressing
OFF	ON	1/2 slot Addressing
OFF	OFF	2-slot Addressing

- Specialty I/O Mode
ON = Discrete (default)
OFF = Block Transfer
- I/O Module Keying
ON = Save Mode (default)
OFF = Check Mode

5.	Insert the 1747-ASB module into the chassis.	Reference
-----------	---	------------------

ATTENTION



Never insert, remove or wire modules with power applied to the chassis or devices wired to the module.

Chapter 5
(Installation and Wiring)

Make sure system power is off; then insert the adapter module into slot 0 of your 1746 chassis.

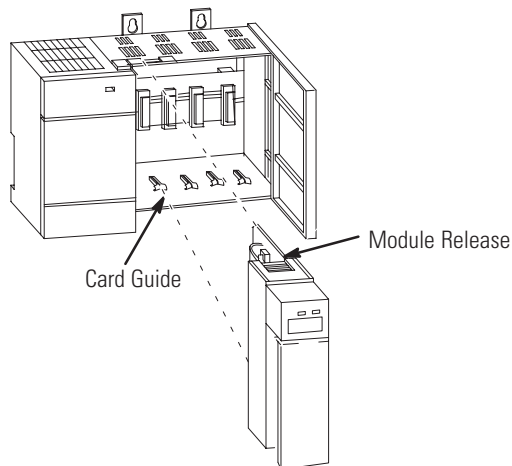

6.	Connect all RIO link devices.	Reference
-----------	--------------------------------------	------------------

Ensure that you:

- Daisy chain each RIO link device.
- Ground the shield drain wire to the nearest chassis mounting bolt.
- Connect the appropriate termination resistors on each end of the link.

Important: Do not connect anything to the NC (No Connect) terminal.

Chapter 5
(Installation and Wiring)

7.	(Optional) Wire a processor restart lockout switch.	Reference
-----------	--	------------------

ATTENTION



Cycling power on any 1747-ASB module chassis removes the processor restart lockout condition (SW-2) by reinitializing the 1747-ASB module.

Chapter 5
(Installation and Wiring)

Use a momentary switch (Class 1, Division 2) to short terminals IN and RET together.
Important: Do not connect anything to the NC (No Connect) terminal.

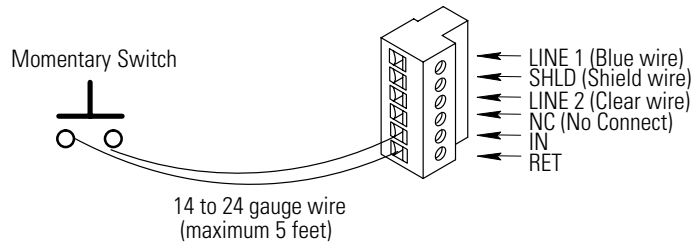

8.	Attach the appropriate I/O Module Addressing Labels.	Reference
-----------	---	------------------

Attach the Remote PLC or Remote SLC label to the outside bottom of each I/O module in your 1747-ASB chassis, as shown below. Fill out each label completely.

Chapter 5
(Installation and Wiring)

Chapter 8
(Application Examples)

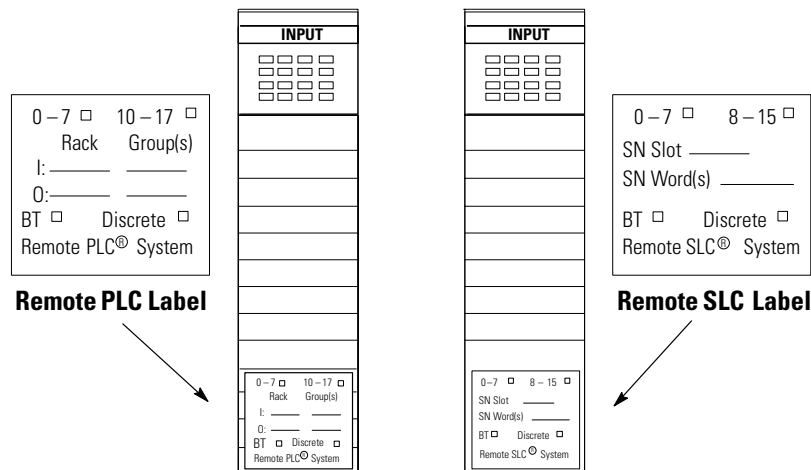

9.	If using a PLC processor as a master, attach the octal labels.	Reference
	The octal filter and door labels must be used when working with a PLC processor as a master. A list of I/O modules that include an octal label kit can be found on page 5-8. Adhere the octal labels over the existing decimal labels, as shown below.	Chapter 5 (Installation and Wiring)

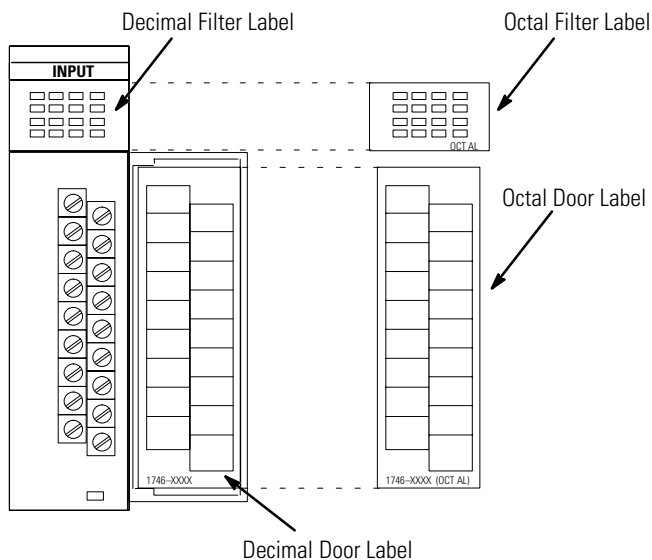

10.	Go through the system start-up procedure.	Reference
------------	--	------------------

ATTENTION



Never insert, remove or wire modules with power applied to the chassis or devices wired to the module.

Follow the steps below:

1. Cycle power one last time in save mode (SW3-8 ON).
2. Remove power from the system.
3. Remove the 1747-ASB module and set SW3-8 to the OFF position (check mode).
4. Replace the 1747-ASB module in slot 0.
5. Apply power to your system.

11.	Check that the module is operating correctly.	Reference
------------	--	------------------

During normal operation (PLC or SLC in Run mode), the 1747-ASB module appears as shown below:

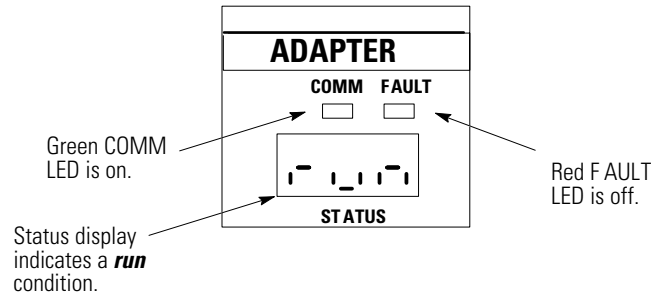

Chapter 6
(Start-Up and Operation)

Chapter 7
(Troubleshooting)

Addressing

This chapter presents:

- slot numbering
- 2-slot, 1-slot, and 1/2-slot addressing
- how I/O module images are mapped

The 1747-ASB module controls 1 remote chassis and up to 2 remote expansion chassis with a maximum of 30 slots. Currently, there are four different types of chassis available.

Chassis Overview

4-Slot

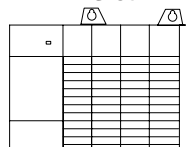

Catalog Number 1746-A4

7-Slot

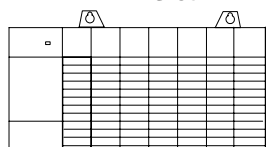

Catalog Number 1746-A7

10-Slot

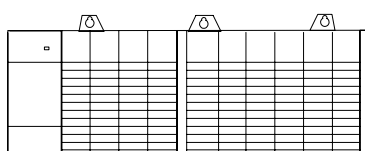

Catalog Number 1746-A10

13-Slot

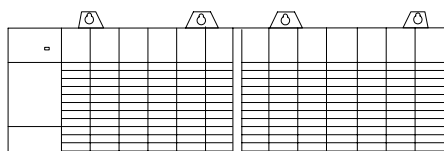

Catalog Number 1746-A13

The first chassis is referred to as the remote chassis. Up to two additional chassis, referred to as remote expansion chassis, can be connected to the remote chassis using a:

- 6 inch cable, Catalog Number 1746-C7
- 36 inch cable, Catalog Number 1746-C9

Each remote chassis and remote expansion chassis requires its own power supply.

IMPORTANT

A 1747-ASB module fault occurs if the remote expansion chassis are not powered.

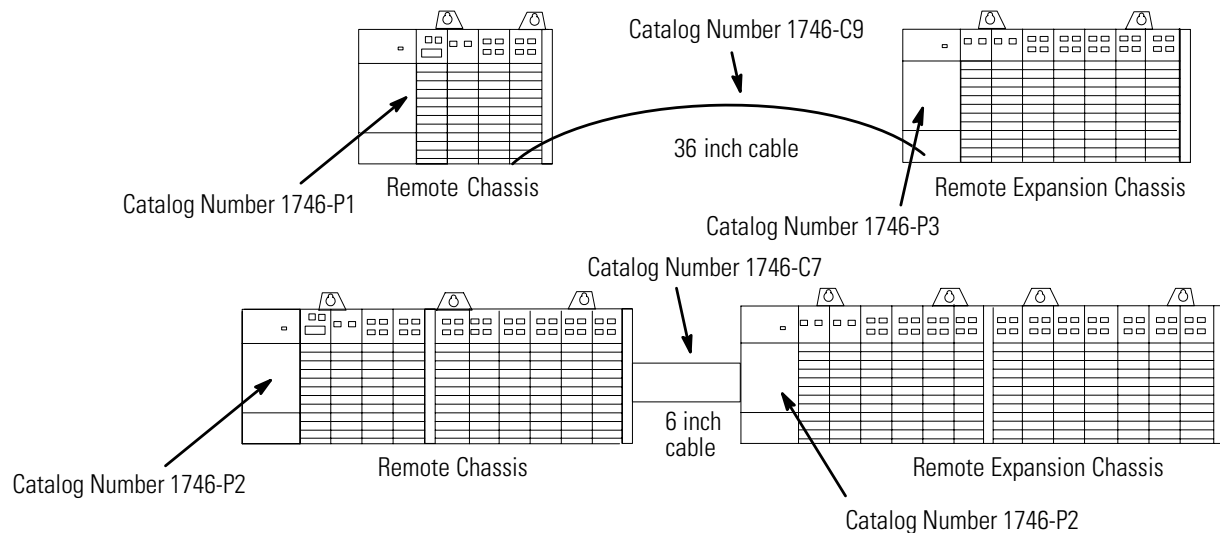

Slot Numbering

The 1747-ASB module is capable of controlling 30 slots. When expansion chassis are used, the 1747-ASB module treats all of the I/O modules as if they are installed in a single chassis.

The remote chassis and remote expansion chassis slots are numbered from 0 to 30. The 1747-ASB module *must* reside in slot 0. Slots numbered 31 and above cannot be used.

IMPORTANT

Installing modules in slots 31 and above causes a 1747-ASB module error.

Addressing I/O Modules

SLC and PLC processors address the I/O modules residing in the 1747-ASB module chassis by logical rack and logical group. Before using the 1747-ASB module, you should first understand slot addressing and how each module's image is mapped into the 1747-ASB module's image.

Slot addressing refers to how each chassis slot is assigned a specific amount of the 1747-ASB module image. The amount depends on which type of slot addressing you choose; 2-slot, 1-slot, and 1/2-slot addressing is available, as shown below:

IMPORTANT

Due to SLC and PLC addressing differences, when the 1747-ASB module is used with an SLC processor, the image bit numbers are 0 to 7, 8 to 15 decimal. When the 1747-ASB module is used with a PLC processor, the image bit numbers are 0 to 7, 10 to 17 octal.

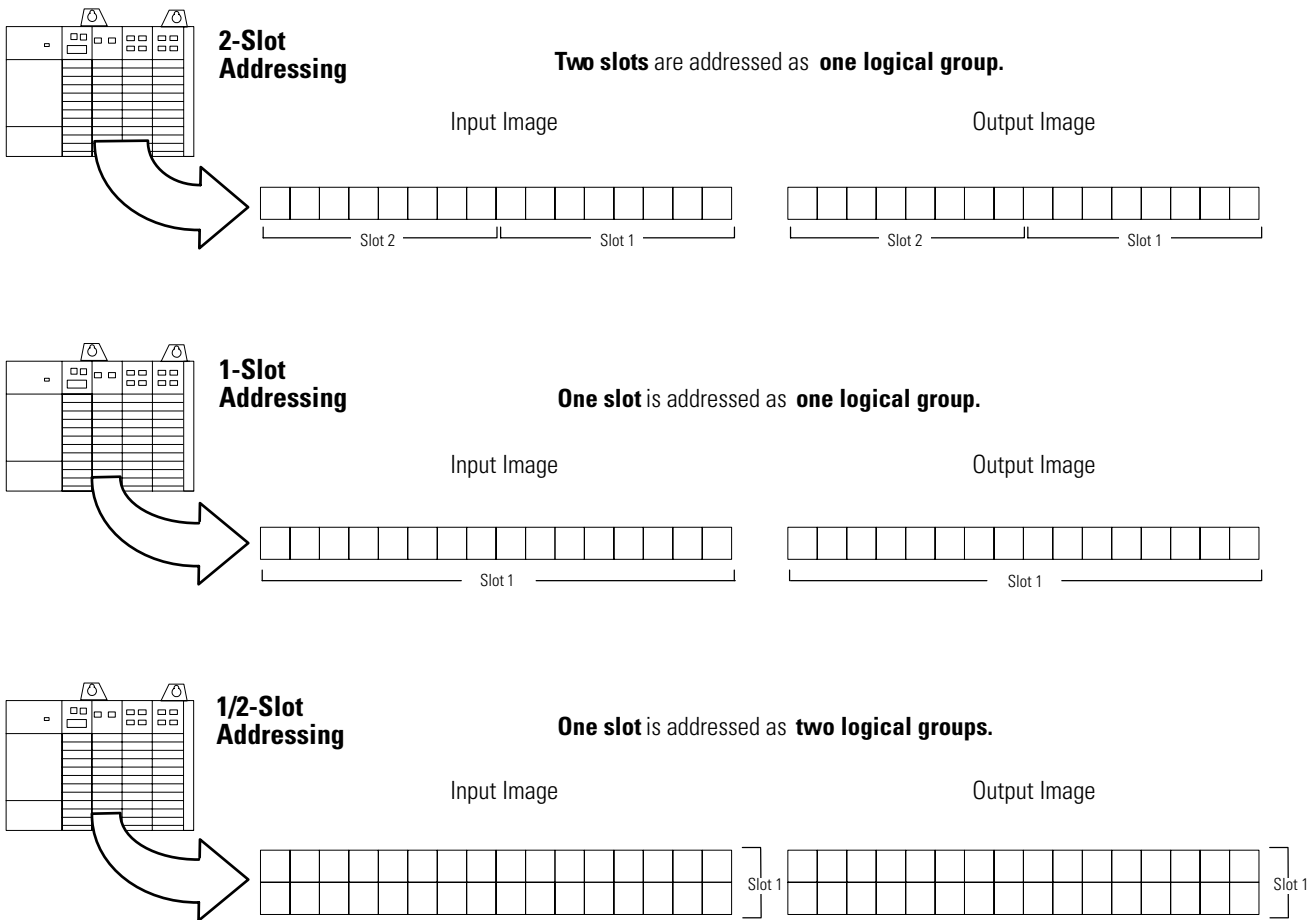

2-Slot Addressing

When the 1747-ASB module is configured for 2-slot addressing, the processor addresses two chassis slots as one logical group. Each slot, beginning with slot 1, is sequentially assigned one byte (8 bits) of the 1747-ASB module's input and output image. Each terminal on a discrete I/O module installed in a slot is assigned a bit within the byte, beginning with the least significant bit. 2-slot addressing is designed to accommodate I/O modules whose image size is one byte or less.

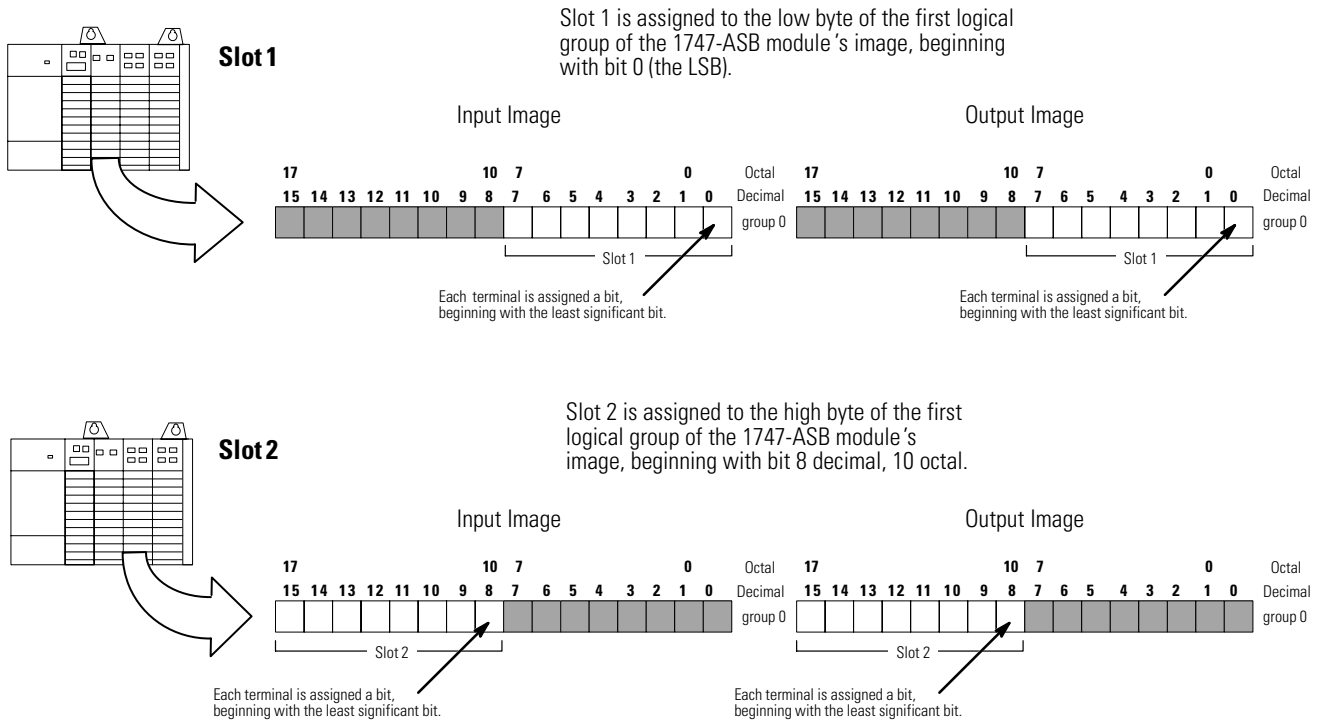

To accommodate modules that require up to one word (16 bits) of input and/or output image, the 1747-ASB module pairs slots beginning with slot 1 (i.e., slot 1 is paired to slot 2, etc.). Slot pairing combines the low and high byte into a one word input and output image. This maximizes I/O image space, allowing you to install an input module in one slot and an output module in the other, each using up to 16 bits of the paired input and output images.

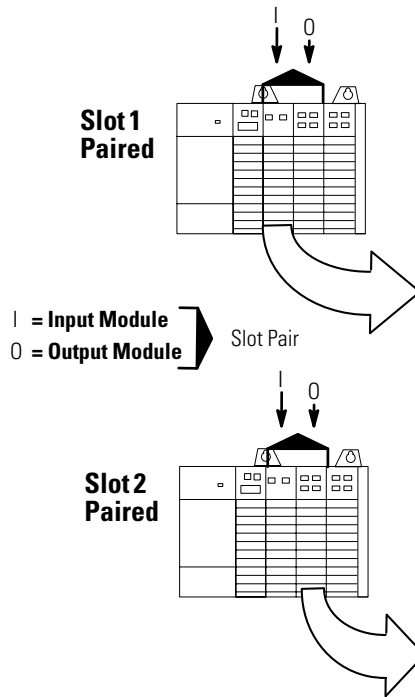

When a module is installed in slot 1 that requires one word of input image, slot 1 uses the input image normally assigned to slots 1 and 2. Slot 2, therefore, cannot use any of its input image. However, slot 2 can now use the output image normally assigned to slots 1 and 2, because slot 1 is not using its portion of the output image.

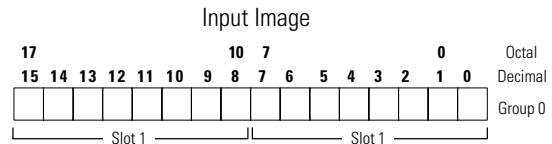

When a module is installed in slot 2 that requires one word of output image, slot 2 uses the output image normally assigned to slots 1 and 2 (if slot 1 is not already using it). The lesser slot number has priority over the greater.

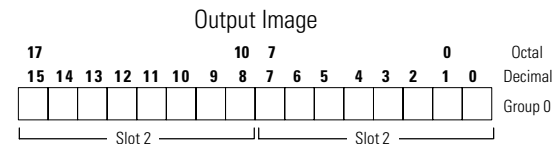

2-Slot Addressing Considerations

When the 1747-ASB module is configured for 2-slot addressing, you can use 4-, 8-, 16-point, combination, and specialty I/O modules. If it is necessary to use 16-point modules, like modules (i.e., two input modules) cannot be installed as a pair. This is because each 16-point module uses a full word in the image. For this reason you must pair an input with an output module. 32-point modules cannot be used. If the discrete mode is selected, specialty I/O modules with one word or less of input and output image are discretely mapped such as the 1747-KE. Specialty I/O modules with two or more words of input or output image are block transfer mapped.

If block transfer mode is selected, all specialty I/O modules are block transfer mapped regardless of their image size.

The 1747-ASB module can block transfer map a maximum of eight words.

2-Slot Addressing Examples

The following example illustrates how to map modules requiring:

- one byte or less of input or output image
- one word of input or output image

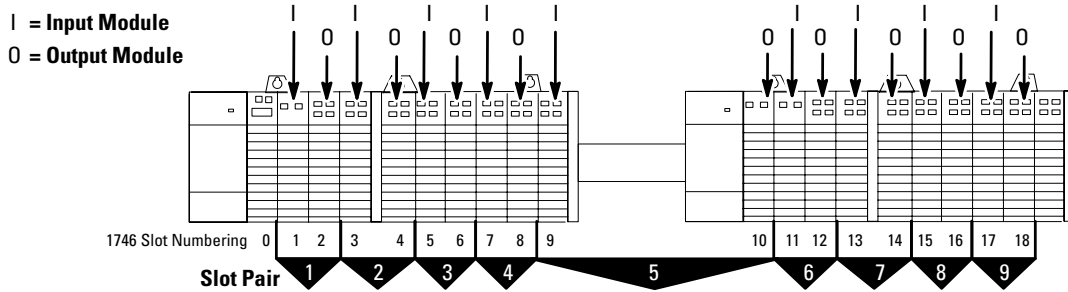

Modules Requiring One Byte

In this example, the modules require one byte of input or output image.

Input modules do not have to be paired with output modules because, in the example to the right, only one byte of input or output image is required.

To use image space more efficiently, slot pairing can be used with 16-point I/O modules as shown below or complementary I/O can be used. Refer to page 4-5.

1747-ASB Input Image

17 15	10 8	7 7	0 0	Octal Decimal
Slot 2	Slot 1			
Slot 4	Slot 3			
Slot 6	Slot 5			
Slot 8	Slot 7			
Slot 10	Slot 9			
Slot 12	Slot 11			
Slot 14	Slot 13			
Slot 16	Slot 15			
Slot 18	Slot 17			

1747-ASB Output Image

17 15	10 8	7 7	0 0	Octal Decimal
Slot 2	Slot 1			SlotPair 1
Slot 4	Slot 3			Slot Pair 2
Slot 6	Slot 5			Slot Pair 3
Slot 8	Slot 7			Slot Pair 4
Slot 10	Slot 9			Slot Pair 5
Slot 12	Slot 11			Slot Pair 6
Slot 14	Slot 13			Slot Pair 7
Slot 16	Slot 15			Slot Pair 8
Slot 18	Slot 17			Slot Pair 9

= unused

1747-ASB Input Image

17 15	10 8	7 7	0 0	Octal Decimal
Slot 1	Slot 1			
Slot 3	Slot 3			
Slot 5	Slot 5			
Slot 7	Slot 7			
Slot 9	Slot 9			
Slot 11	Slot 11			
Slot 13	Slot 13			
Slot 15	Slot 15			
Slot 17	Slot 17			

1747-ASB Output Image

17 15	10 8	7 7	0 0	Octal Decimal
Slot 2	Slot 2			SlotPair 1
Slot 4	Slot 4			Slot Pair 2
Slot 6	Slot 6			Slot Pair 3
Slot 8	Slot 8			Slot Pair 4
Slot 10	Slot 10			Slot Pair 5
Slot 12	Slot 12			Slot Pair 6
Slot 14	Slot 14			Slot Pair 7
Slot 16	Slot 16			Slot Pair 8
Slot 18	Slot 18			Slot Pair 9

Modules Requiring One Word

In this example, the modules require one word of input or output image.

Input modules must be paired with output modules to ensure the paired modules do not use the same image locations.

If images overlap, a 1747-ASB module error occurs. For example, if 16 point input modules are installed in slots 1 and 2, their input images overlap and a 1747-ASB module error occurs.

1-Slot Addressing

When the 1747-ASB module is configured for 1-slot addressing, the processor addresses one chassis slot as one logical group. Each slot, beginning with slot one, is sequentially assigned one word (16 bits) of the 1747-ASB module's input and output image. Each terminal on the I/O module is assigned a bit within the word, beginning with the least significant bit. One-slot addressing is primarily designed to accommodate I/O modules whose image size is less than or equal to one word but more than one byte.

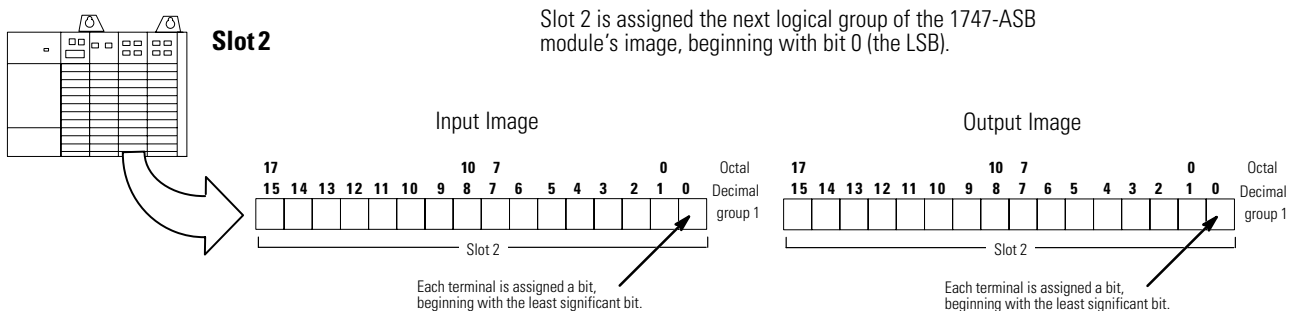
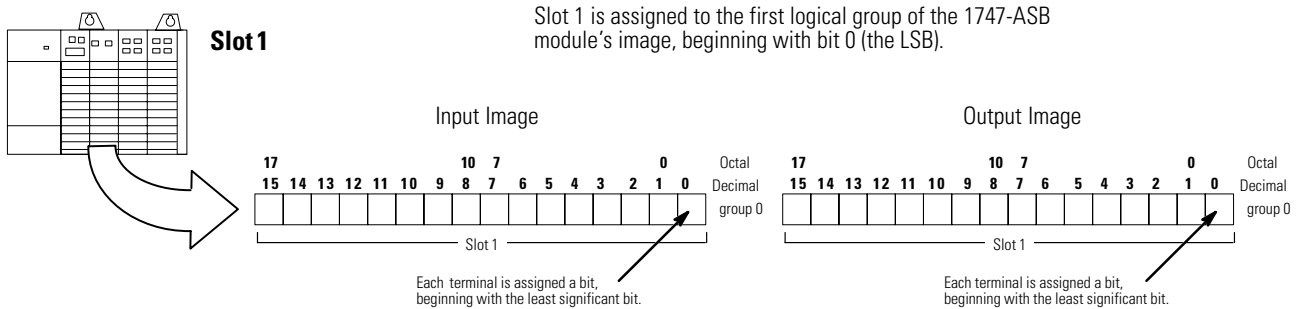

To accommodate modules that require up to two words (32 bits) of input and/or output image, the 1747-ASB module pairs slots beginning with slot 1 (i.e., slot 1 paired to slot 2, etc.). Slot pairing combines both words (of either the input or output image, whichever is required) and assigns them to one slot. This maximizes I/O image space, allowing you to install an input module in one slot and an output module in the other, each using up to 32 bits of the paired input and output images.

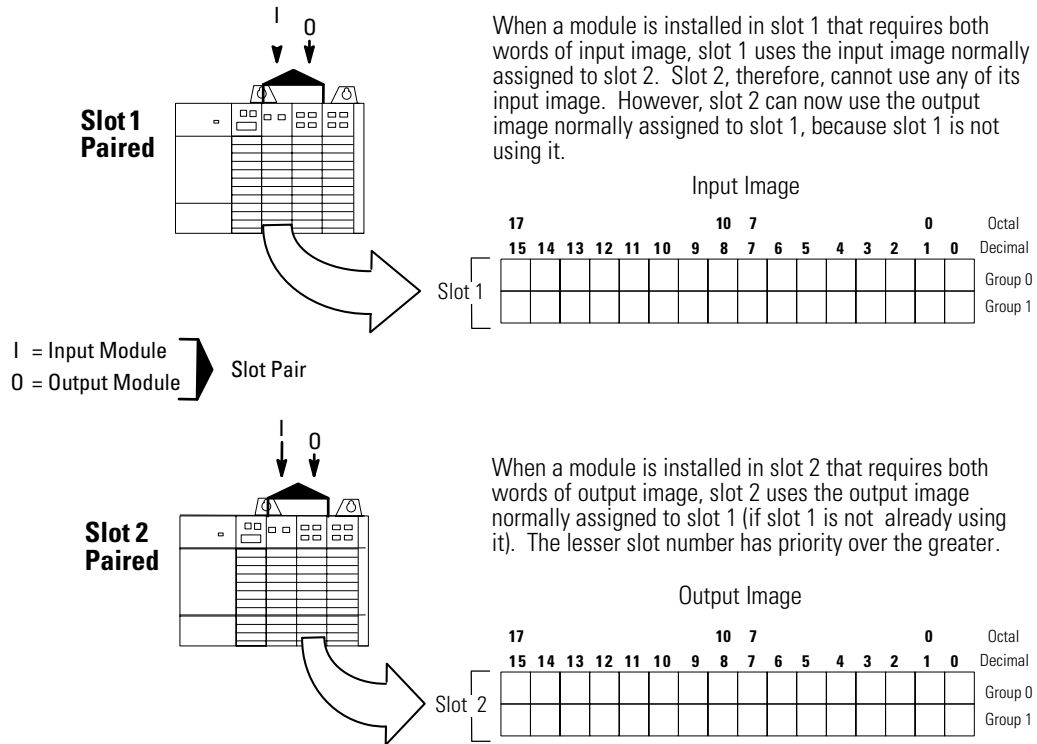

1-Slot Addressing Considerations

When the 1747-ASB module is configured for 1-slot addressing, you can use 4, 8, 16 point, 32 point discrete and discrete combination, discrete and block transfer specialty I/O modules.

Like 32 point modules (i.e., two input modules) cannot be installed as a pair because both slots cannot use the same image location. For example, if you use a 32 point input module that requires two words of the image, the other module within the pair must be an output module.

If the discrete mode is selected, specialty I/O modules with two words or less of input and output image are discretely mapped such as the 1746-NIO4I. However, with a combination specialty module such as the 1746-NIO4I, the adjacent slot must be empty. Specialty I/O modules with more than two words of input or output image are block transfer mapped such as the 1746-NI4, -NO4I, -NO4V, and -HS.

If the block transfer mode is selected, all specialty I/O modules are block transfer mapped regardless of their image size.

The 1747-ASB module can block transfer map a maximum of eight words.

1-Slot Addressing Examples

The following example illustrates how to map modules requiring:

- *one word* of input or output image
- *more than one word* of input or output image

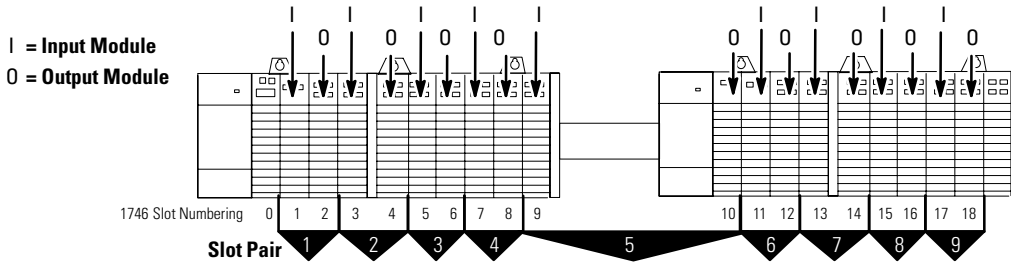

Modules Requiring One Word

In the example below, the modules require one word of input or output image. Input modules do not have to be paired with output modules, because in this example, only one word of input and output image is required.

To reduce unused image space, slot pairing can be used with 32-point I/O modules or the system can be configured for complementary I/O. For more information, refer to the complementary I/O description found on page 4-5.

Modules Requiring More Than One Word

In the example below, the modules require more than one word of input or output image.

Input modules must be paired with output modules so their input and output images do not overlap.

1747-ASB Input Image

17	15	10	7	0	Octal	Decimal
Slot 1	Slot 1	1				
Slot 2	Slot 2	2				
Slot 3	Slot 3	3				
Slot 4	Slot 4	4				
Slot 5	Slot 5	5				
Slot 6	Slot 6	6				
Slot 7	Slot 7	7				
Slot 8	Slot 8	8				
Slot 9	Slot 9	9				
Slot 10	Slot 10					
Slot 11	Slot 11					
Slot 12	Slot 12					
Slot 13	Slot 13					
Slot 14	Slot 14					
Slot 15	Slot 15					
Slot 16	Slot 16					
Slot 17	Slot 17					
Slot 18	Slot 18					

1747-ASB Output Image

17	15	10	7	0	Octal	Decimal
Slot 1	Slot 1	1				
Slot 2	Slot 2	2				
Slot 3	Slot 3	3				
Slot 4	Slot 4	4				
Slot 5	Slot 5	5				
Slot 6	Slot 6	6				
Slot 7	Slot 7	7				
Slot 8	Slot 8	8				
Slot 9	Slot 9	9				
Slot 10	Slot 10					
Slot 11	Slot 11					
Slot 12	Slot 12					
Slot 13	Slot 13					
Slot 14	Slot 14					
Slot 15	Slot 15					
Slot 16	Slot 16					
Slot 17	Slot 17					
Slot 18	Slot 18					

1747-ASB Input Image

17	15	10	7	0	Octal	Decimal
Slot 1	Slot 1	1				
Slot 1	Slot 1	2				
Slot 3	Slot 3	3				
Slot 5	Slot 5	4				
Slot 5	Slot 5	5				
Slot 7	Slot 7	6				
Slot 7	Slot 7	7				
Slot 9	Slot 9	8				
Slot 9	Slot 9	9				
Slot 11	Slot 11					
Slot 11	Slot 11					
Slot 13	Slot 13					
Slot 13	Slot 13					
Slot 15	Slot 15					
Slot 15	Slot 15					
Slot 17	Slot 17					
Slot 17	Slot 17					

1747-ASB Output Image

17	15	10	7	0	Octal	Decimal
Slot 2	Slot 2	1				
Slot 2	Slot 2	2				
Slot 4	Slot 4	3				
Slot 4	Slot 4	4				
Slot 6	Slot 6	5				
Slot 6	Slot 6	6				
Slot 8	Slot 8	7				
Slot 8	Slot 8	8				
Slot 10	Slot 10	9				
Slot 10	Slot 10					
Slot 12	Slot 12					
Slot 12	Slot 12					
Slot 14	Slot 14					
Slot 14	Slot 14					
Slot 16	Slot 16					
Slot 16	Slot 16					
Slot 18	Slot 18					
Slot 18	Slot 18					

□ = unused

If images overlap, a 1747-ASB module error occurs. For example, if 32-point input modules are installed in slots 1 and 2, their input images overlap and a 1747-ASB module error occurs.

1/2-Slot Addressing

When the 1747-ASB module is configured for 1/2-slot addressing, the processor addresses one chassis slot as two logical groups. Each slot, beginning with slot one, is sequentially assigned two words (32 bits) of the 1747-ASB module's input and output image. Each terminal on the I/O module is assigned a bit within the word, beginning with the least significant bit. 1/2-slot addressing is designed to accommodate I/O modules whose image size is less than or equal to two words but more than one word.

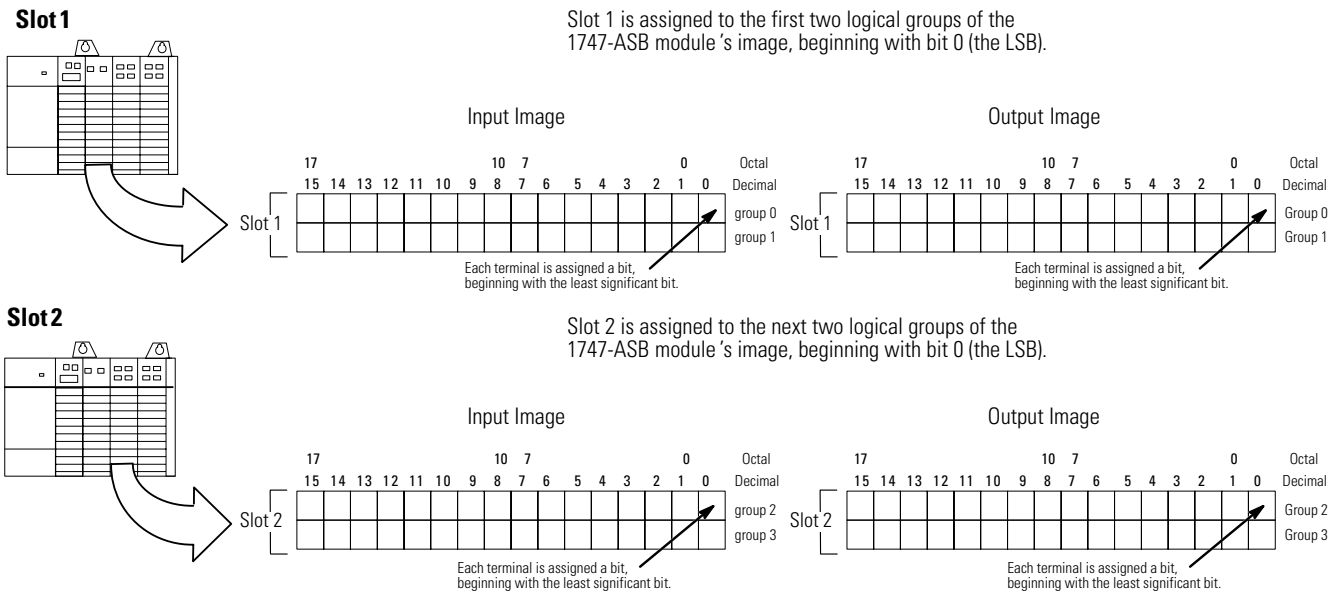

To accommodate modules that require up to four words of input and/or output image, the 1747-ASB module pairs slots beginning with slot one (i.e., slot 1 is paired to slot 2, etc.). Slot pairing combines the two words assigned to each slot (of either the input or output image, whichever is required) and assigns all four words to one slot. This maximizes I/O image space, allowing you to install an input module in one slot and an output module in the other, each using up to four words of the paired input and output images.

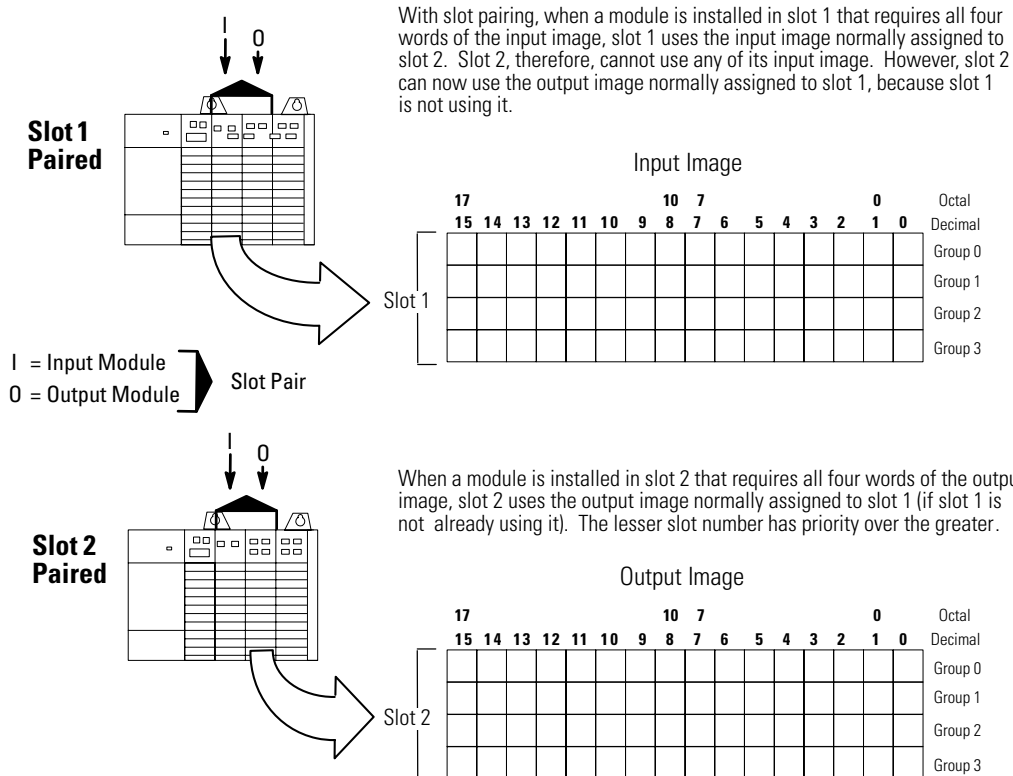

With slot pairing, when a module is installed in slot 1 that requires all four words of the input image, slot 1 uses the input image normally assigned to slot 2. Slot 2, therefore, cannot use any of its input image. However, slot 2 can now use the output image normally assigned to slot 1, because slot 1 is not using it.

When a module is installed in slot 2 that requires all four words of the output image, slot 2 uses the output image normally assigned to slot 1 (if slot 1 is not already using it). The lesser slot number has priority over the greater.

1/2-Slot Addressing Considerations

When the 1747-ASB module is configured for 1/2-slot addressing, you can use 4-, 8-, 16-, 32-point, discrete combination and specialty I/O modules in any slot.

If the discrete mode is selected, specialty modules with four words or less of input or output image are discretely mapped such as the 1746-NI4, -NO4I, -NO4V, and -HS. However, with a specialty module such as the 1746-HS, the adjacent slot must be empty. Specialty modules with more than four words of input or output image are block transfer mapped such as the 1746-BAS.

If the block transfer mode is selected, all specialty modules are block transfer mapped regardless of the image size.

The 1747-ASB module can block transfer map a maximum of eight words.

1/2-Slot Addressing Examples

The following example illustrates how to map modules requiring:

- *two words* of input or output image
- *more than two words* of input or output image

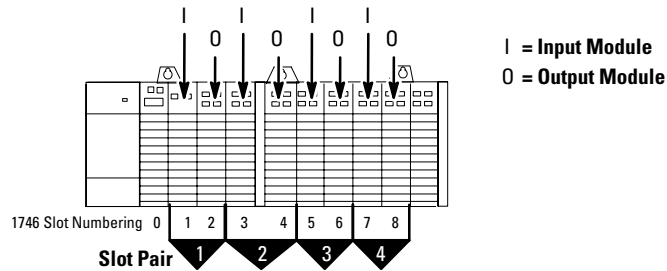

Modules Requiring Two Words

In the example below, the modules require two words of input or output image.

If you would like to know how you can use the unused input or output images, refer to the complementary I/O description, found on page 4-5.

Modules Requiring More Than Two Words

In this example, the modules require more than two words of input or output image.

Input modules must be paired with output modules so their input or output images do not overlap.

1747-ASB Input Image

17	10	7	0	Octal
15	8	7	0	Decimal
Slot 1	Slot 1	1	1	Slot Pair
Slot 1	Slot 1			
Slot 2	Slot 2	2	2	
Slot 2	Slot 2			
Slot 3	Slot 3	3	3	
Slot 3	Slot 3			
Slot 4	Slot 4	4	4	
Slot 4	Slot 4			
Slot 5	Slot 5	3	3	
Slot 5	Slot 5			
Slot 6	Slot 6	3	3	
Slot 6	Slot 6			
Slot 7	Slot 7	4	4	
Slot 7	Slot 7			
Slot 8	Slot 8	4	4	
Slot 8	Slot 8			

1747-ASB Output Image

17	10	7	0	Octal
15	8	7	0	Decimal
Slot 1	Slot 1	1	1	Slot Pair
Slot 1	Slot 1			
Slot 2	Slot 2	2	2	
Slot 2	Slot 2			
Slot 3	Slot 3	3	3	
Slot 3	Slot 3			
Slot 4	Slot 4	4	4	
Slot 4	Slot 4			
Slot 5	Slot 5	3	3	
Slot 5	Slot 5			
Slot 6	Slot 6	3	3	
Slot 6	Slot 6			
Slot 7	Slot 7	4	4	
Slot 7	Slot 7			
Slot 8	Slot 8	4	4	
Slot 8	Slot 8			

1747-ASB Input Image

17	10	7	0	Octal
15	8	7	0	Decimal
Slot 1	Slot 1	1	1	Slot Pair
Slot 1	Slot 1			
Slot 1	Slot 1	2	2	
Slot 3	Slot 3			
Slot 3	Slot 3	3	3	
Slot 3	Slot 3			
Slot 5	Slot 5	3	3	
Slot 5	Slot 5			
Slot 5	Slot 5	4	4	
Slot 5	Slot 5			
Slot 7	Slot 7	4	4	
Slot 7	Slot 7			
Slot 7	Slot 7	4	4	
Slot 7	Slot 7			

1747-ASB Output Image

17	10	7	0	Octal
15	8	7	0	Decimal
Slot 2	Slot 2	1	2	Slot Pair
Slot 2	Slot 2			
Slot 2	Slot 2	2	2	
Slot 4	Slot 4			
Slot 4	Slot 4	3	3	
Slot 4	Slot 4			
Slot 6	Slot 6	3	3	
Slot 6	Slot 6			
Slot 6	Slot 6	4	4	
Slot 6	Slot 6			
Slot 8	Slot 8	4	4	
Slot 8	Slot 8			
Slot 8	Slot 8	4	4	
Slot 8	Slot 8			

□ = unused

How I/O Module Images Are Mapped

The method of transferring an I/O module's image to the 1747-ASB module's image is referred to as image mapping, or mapping. An I/O image can be discretely mapped or block transfer mapped. How the module's image is mapped depends on the type of module you are using (discrete or specialty I/O).

The following table lists all of the different types of I/O modules currently supported by the 1747-ASB module.

I/O Module	Type of Module
4-point discrete I/O	Discrete
8-point discrete I/O	Discrete
16-point discrete I/O	Discrete
32-point discrete I/O	Discrete
Combination discrete I/O	Discrete
Analog I/O	Specialty
BASIC Module	Specialty
IMC 110 Servo Motion Control Module	Specialty
Distributed I/O Scanner Module	Specialty
Direct Communications Module	Specialty
KE Communications Module	Specialty
Thermocouple/mV Module	Specialty
RTD/Resistance Module	Specialty
Stepper Controller Module	Specialty

How Discrete I/O Modules Are Mapped

Discrete I/O images are exchanged with either the SLC *or* PLC scanner using RIO discrete transfers. Discrete I/O module images are *always* discretely mapped to the 1747-ASB module image. Discrete I/O images are mapped into the assigned image space beginning with the least significant bit. The example below assumes 1-slot addressing starting at logical group zero.

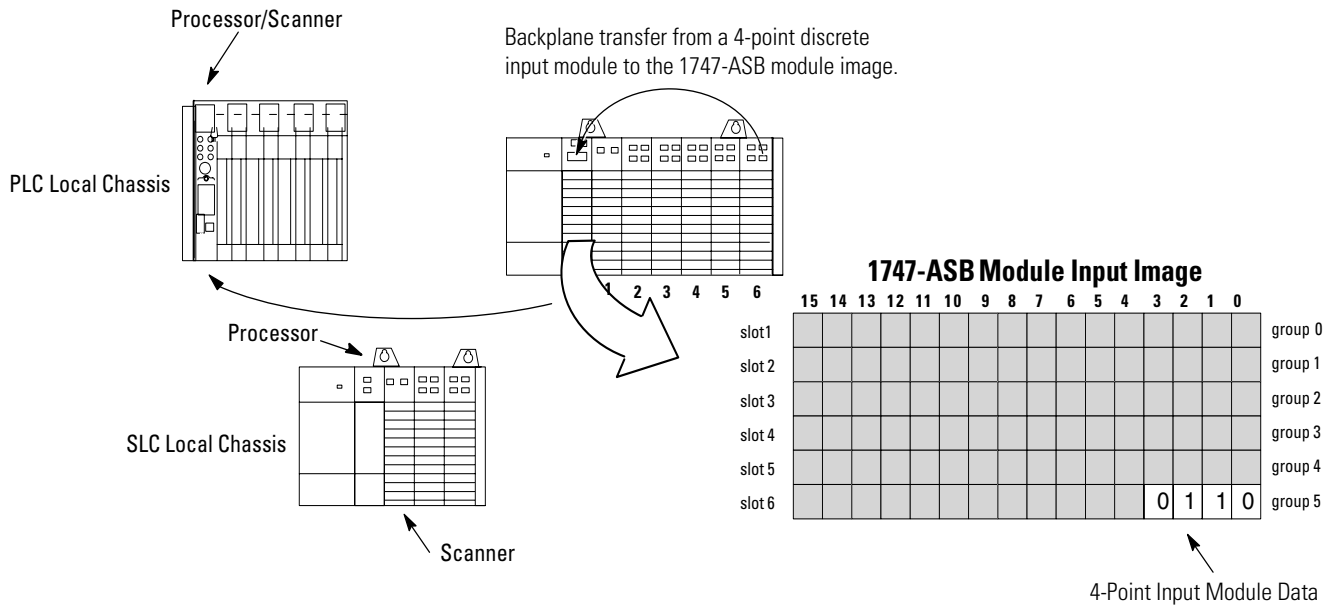

How Specialty I/O Module Images Are Mapped

Specialty I/O module images are discretely mapped or block transfer mapped, depending on the specialty I/O mode you have selected for the 1747-ASB module. SW3-7 provides two specialty I/O modes, discrete and block transfer.

When Block Transfer Mode is Selected

The advantage of using block transfer mode is that it only requires one byte of the 1747-ASB module's input and output image. However, you must add block transfer instructions to your PLC user program, and block transfer times are generally longer than discrete transfer times.

When block transfer mode is selected, all specialty modules that are block transfer mapped use one byte in the 1747-ASB module's input and output image. These bytes reside in the least significant byte of the 1747-ASB image reserved for the module's slot.

When a module is block transfer mapped, the module's input and output image is transferred on the RIO link using RIO block transfers. RIO block transfers are processed by the scanner and 1747-ASB module. The 1747-ASB module transfers the specialty I/O modules image by way of a backplane scan. The 1747-ASB module then transfers the image to the scanner using RIO block transfers.

The scanner and 1747-ASB module process a maximum of one RIO block transfer per logical device per RIO scan. If you wish to perform four RIO block transfers for a logical device, at least four RIO scans are required to complete these RIO block transfers.

The 1747-ASB module can block transfer up to a maximum of 8 words per block transfer.

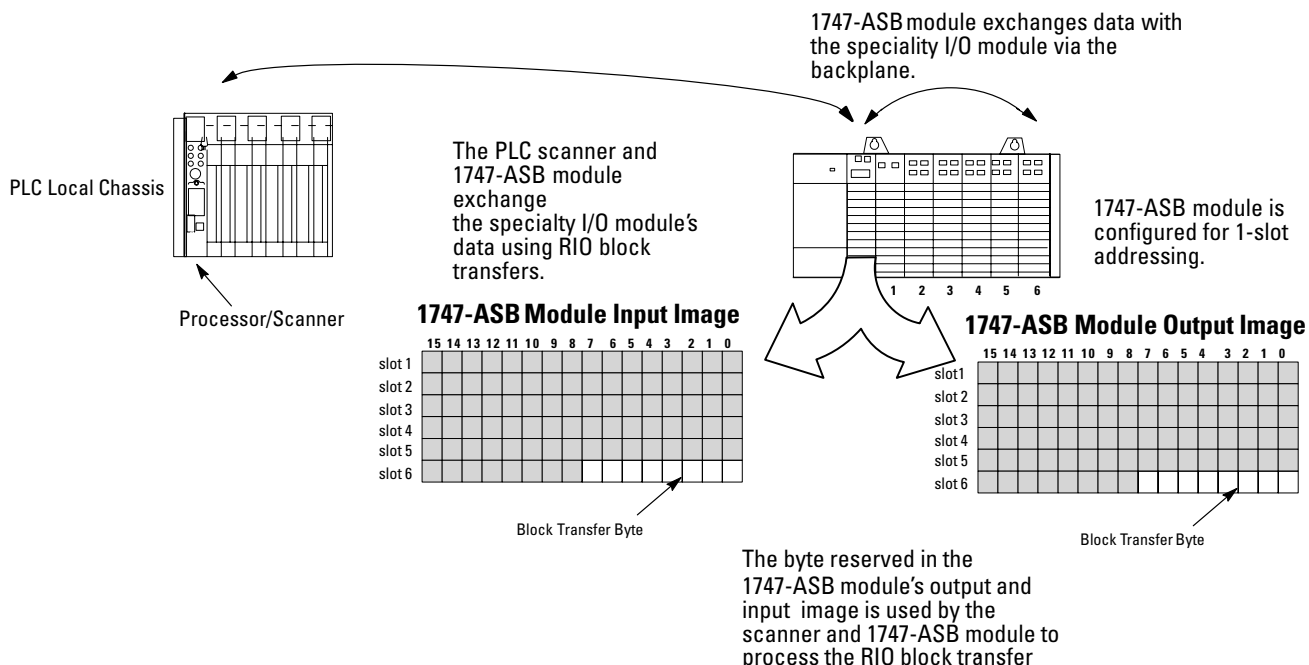

The 1747-ASB module processes RIO block transfers that are less than or equal to the specialty I/O module's image size. For example, if a four word specialty I/O module is block transfer mapped, the 1747-ASB module accepts RIO block transfer reads for this module if they are less than or equal to four words. RIO block transfers always begin reading or writing word 0 (least significant word) of the module's image.

An RIO block transfer size of zero will cause all of the module's image to be transferred.

When Discrete Mode is Selected

The advantage of discrete mode is that no programming is required for data transfer. However, discrete mode requires more 1747-ASB module image space than block transfer mode.

When discrete mode is selected, specialty I/O modules are discretely mapped or block transfer mapped, depending on:

- the specialty I/O module's image size
- the addressing mode selected (2-slot, 1-slot, or 1/2-slot)

When discrete mode is selected, a specialty I/O module is discretely mapped *if* its image fits into the image space assigned to its slot pair.

For example, if the specialty I/O module such as the 1746-NIO4I and -NIO4V requires two words of input and output image, and the 1747-ASB module is configured for 1-slot addressing, which provides two words of input and output image per slot pair, the specialty I/O module is discretely mapped. However, if four words of input or output image are required, the specialty I/O module such as the 1746-NI4, -NO4V, -NO4I, and -HS, are block transfer mapped.

RIO Discrete Mapping

Two words of input and output image are required by the specialty I/O module. The 1747-ASB module is configured for 1-slot addressing, which provides two words of input and output image per slot pair. Because the specialty I/O module's image can be mapped into the provided image, the specialty I/O module is discretely mapped. The other slot of the pair is empty since all of the input and output image is used.

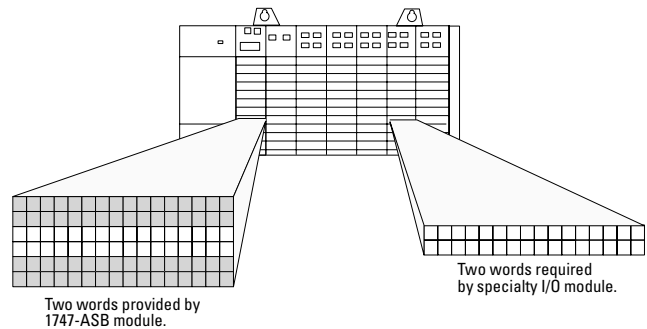

RIO Block Transfer Mapping

Four words of input and output image are required by the specialty I/O module. The 1747-ASB module is configured for 1-slot addressing, which provides two words of input and output image per slot pair. Because the specialty I/O module's image cannot be mapped into the provided image, the specialty I/O module is block transfer mapped.

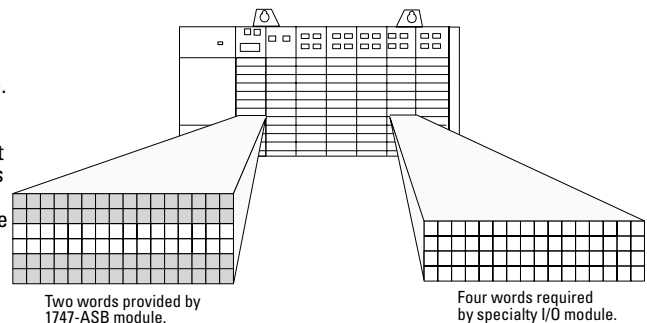

Due to the module's image size, some specialty I/O modules are always block transfer mapped.

The following table provides the specialty I/O module mapping used when discrete mode is selected.

Max. Specialty I/O Module Image Size	Addressing Mode	Specialty I/O Module Mapping	I/O Module Examples
1 Word	2-slot	Discrete	1747-KE
	1-slot	Discrete	
	1/2-slot	Discrete	
2 Words	2-slot	Block transfer	1746-NIO4I, -NIO4V
	1-slot	Discrete	
	1/2-slot	Discrete	
3 or 4 Words	2-slot	Block transfer	1746-NI4, -NO4V, -IMC110
	1-slot	Block transfer	
	1/2-slot	Discrete	
5 to 8 Words	2-slot	Block transfer	1746-BAS, -NR4, -NT4, -HSTP1 1747-DCM
	1-slot	Block transfer	
	1/2-slot	Block transfer	

The 1747-ASB module can block transfer map a maximum of eight words.

Configuration

This chapter presents the configuration options made through the various DIP switch settings.

DIP Switch Information

The 1747-ASB module parameters are configured by three DIP switches, shown below. To assist you in the configuration of multiple 1747-ASB modules, a configuration worksheet is provided in Appendix C.

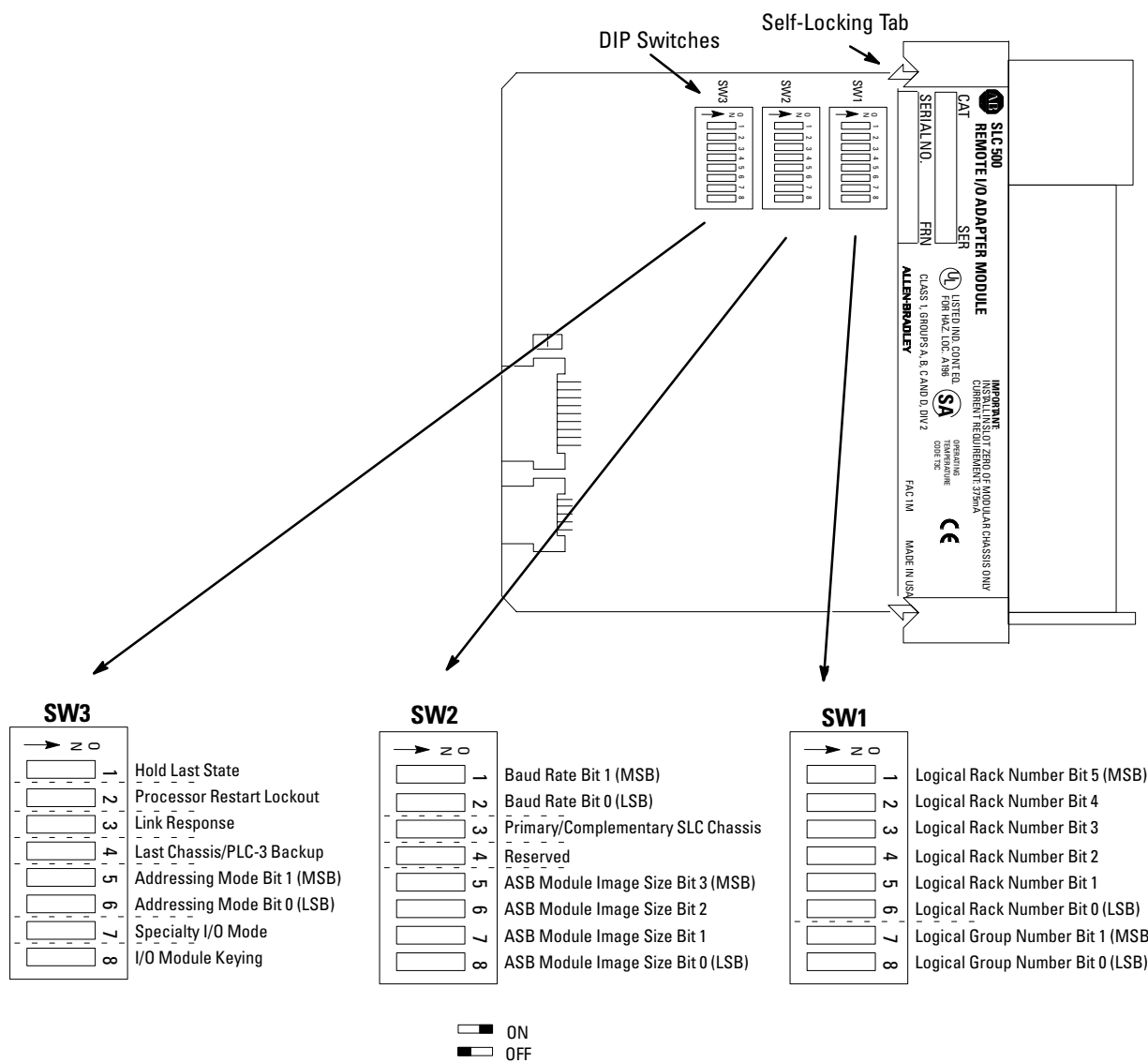

DIP Switch SW1

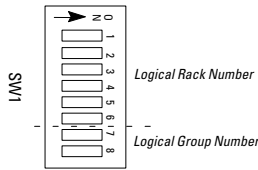

Logical Rack Number (SW1-1 through 6)

SW1 switches 1 through 6 assign the 1747-ASB module a starting logical rack number in the scanner's image.

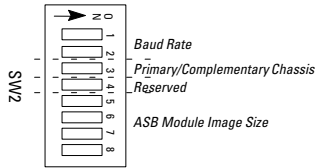

When configured as a complementary chassis (SW2 switch 3), the 1747-ASB module can appear on the RIO link as any starting logical rack between 0 and 62 (0 to 76 octal).

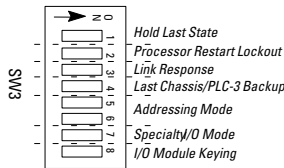

When configured as a primary chassis (SW2 switch 3), the 1747-ASB module can appear on the RIO link as any starting logical rack between 0 and 7.

Logical rack one is the default setting as shipped from the factory.

ON
 OFF

The following table provides the logical rack numbers for PLC processors.

1747-SN	Logical Rack Number (Octal)							Switch Number (SW1)					
	PLC 2	PLC 3	PLC 5/15	PLC 5/25	PLC 5/40	PLC 5/60	PLC 5/250	1	2	3	4	5	6
0	1	0	-	-	-	-	0	ON	ON	ON	ON	ON	ON
1	2	1	1	1	1	1	1	ON	ON	ON	ON	ON	OFF
2	3	2	2	2	2	2	2	ON	ON	ON	ON	OFF	ON
3	4	3	3	3	3	3	3	ON	ON	ON	ON	OFF	OFF
	5	4		4	4	4	4	ON	ON	ON	OFF	ON	ON
	6	5		5	5	5	5	ON	ON	ON	OFF	ON	OFF
	7	6		6	6	6	6	ON	ON	ON	OFF	OFF	ON
		7		7	7	7	7	ON	ON	ON	OFF	OFF	OFF
		10			10	10	10	ON	ON	OFF	ON	ON	ON
		11			11	11	11	ON	ON	OFF	ON	ON	OFF
		12			12	12	12	ON	ON	OFF	ON	OFF	ON
		13			13	13	13	ON	ON	OFF	ON	OFF	OFF
		14			14	14	14	ON	ON	OFF	OFF	ON	ON
		15			15	15	15	ON	ON	OFF	OFF	ON	OFF
		16			16	16	16	ON	ON	OFF	OFF	OFF	ON
		17			17	17	17	ON	ON	OFF	OFF	OFF	OFF
		20				20	20	ON	OFF	ON	ON	ON	ON
		21				21	21	ON	OFF	ON	ON	ON	OFF
		22				22	22	ON	OFF	ON	ON	OFF	ON
		23				23	23	ON	OFF	ON	ON	OFF	OFF
		24				24	24	ON	OFF	ON	OFF	ON	ON
		25				25	25	ON	OFF	ON	OFF	ON	OFF
		26				26	26	ON	OFF	ON	OFF	OFF	ON

Logical Rack Number (Octal)								Switch Number (SW1)					
1747-SN	PLC 2	PLC 3	PLC 5/15	PLC 5/25	PLC 5/40	PLC 5/60	PLC 5/250	1	2	3	4	5	6
		27				27	27	ON	OFF	ON	OFF	OFF	OFF
		30					30	ON	OFF	OFF	ON	ON	ON
		31					31	ON	OFF	OFF	ON	ON	OFF
		32					32	ON	OFF	OFF	ON	OFF	ON
		33					33	ON	OFF	OFF	ON	OFF	OFF
		34					34	ON	OFF	OFF	OFF	ON	ON
		35					35	ON	OFF	OFF	OFF	ON	OFF
		36					36	ON	OFF	OFF	OFF	OFF	ON
		37					37	ON	OFF	OFF	OFF	OFF	OFF
		40						OFF	ON	ON	ON	ON	ON
		41						OFF	ON	ON	ON	ON	OFF
		42						OFF	ON	ON	ON	OFF	ON
		43						OFF	ON	ON	ON	OFF	OFF
		44						OFF	ON	ON	OFF	ON	ON
		45						OFF	ON	ON	OFF	ON	OFF
		46						OFF	ON	ON	OFF	OFF	ON
		47						OFF	ON	ON	OFF	OFF	OFF
		50						OFF	ON	OFF	ON	ON	ON
		51						OFF	ON	OFF	ON	ON	OFF
		52						OFF	ON	OFF	ON	OFF	ON
		53						OFF	ON	OFF	ON	OFF	OFF
		54						OFF	ON	OFF	OFF	ON	ON
		55						OFF	ON	OFF	OFF	ON	OFF
		56						OFF	ON	OFF	OFF	OFF	ON
		57						OFF	ON	OFF	OFF	OFF	OFF
		60						OFF	OFF	ON	ON	ON	ON
		61						OFF	OFF	ON	ON	ON	OFF
		62						OFF	OFF	ON	ON	OFF	ON
		63						OFF	OFF	ON	ON	OFF	OFF
		64						OFF	OFF	ON	OFF	ON	ON
		65						OFF	OFF	ON	OFF	ON	OFF
		66						OFF	OFF	ON	OFF	OFF	ON
		67						OFF	OFF	ON	OFF	OFF	OFF
		70						OFF	OFF	OFF	ON	ON	ON
		71						OFF	OFF	OFF	ON	ON	OFF
		72						OFF	OFF	OFF	ON	OFF	ON
		73						OFF	OFF	OFF	ON	OFF	OFF
		74						OFF	OFF	OFF	OFF	ON	ON
		75						OFF	OFF	OFF	OFF	ON	OFF
		76						OFF	OFF	OFF	OFF	OFF	ON
77	77	77	77	77	77	77	77	Reserved					

Logical Group Number (SW1-7,8)

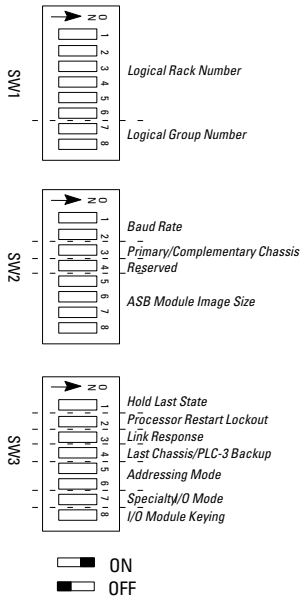

SW1 switches 7 and 8 determine the starting logical group.

Valid starting logical group numbers are determined by the:

- addressing mode (2-slot, 1-slot, or 1/2-slot)
- specialty I/O mode (discrete or block transfer)

The default position is logical group zero as shipped from the factory.

Addressing Mode	Specialty I/O Mode	Valid Starting Logical Groups
2-slot, 1-slot, 1/2-slot	Block Transfer	0, 2, 4, 6
2-slot, 1-slot	Discrete	0, 2, 4, 6
1/2-slot	Discrete	0, 4

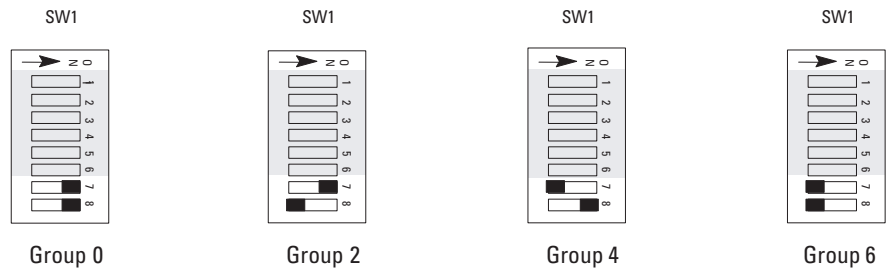

If an *invalid* starting logical group number is selected, an error occurs.

DIP Switch SW2

Baud Rate (SW2-1,2)

SW2 switches 1 and 2 determine the baud rate the 1747-ASB module operates at while communicating across the RIO link.

The default is 57.6K as shipped from the factory.

Baud Rate	Maximum Cable Distance (Belden 9463)
57.6K baud	3048 meters (10,000 feet)
115.2K baud	1524 meters (5,000 feet)
230.4K baud	762 meters (2,500 feet)

Baud Rate DIP Switch Settings

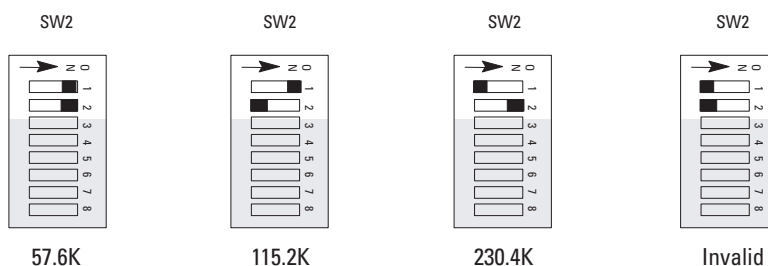

If the invalid switch setting is selected, a 1747-ASB module error occurs.

Primary/Complementary Chassis (SW2-3)

SW2 switch 3 determines whether the 1747-ASB module appears to the scanner as a primary or complementary chassis.

Primary/Complementary SLC Chassis DIP Switch Setting

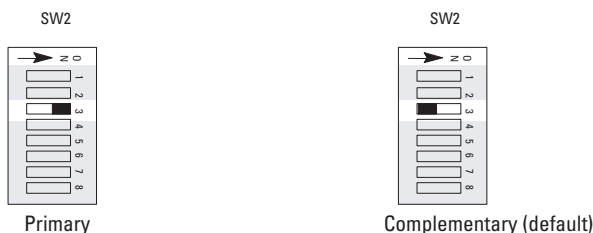
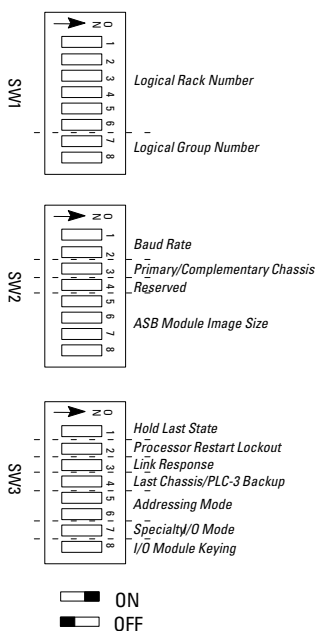

If you are not using complementary I/O, all 1747-ASB modules should be configured with SW2-3 in the default position. If a primary chassis is configured and no complementary chassis exists, the scanner wastes time trying to scan a complementary chassis that is not there.

Complementary I/O allows two 1747-ASB modules to overlap their input and output images, creating one image within the scanner, thus maximizing image space. The combined image is located where the primary image is configured to reside. Complementary I/O is very useful when portions of your input and output images are unused.

ATTENTION



Because the primary and complementary chassis images overlap, input and specialty I/O modules must never share the same image location. Inputs received by the scanner may be incorrect and RIO block transfers are not serviced properly.

If an output module shares its output image with another output module, both output modules receive the same output information.

If you want to use complementary I/O, two 1747-ASB modules are required. One 1747-ASB module is configured as a primary chassis, the other as a complementary chassis. If a primary chassis exists, it is scanned first.

The 1747-ASB modules in the primary and complementary chassis *must* be configured to have the same:

- addressing mode, using SW3-5,6
- logical group number, using SW1-7,8
- baud rate, using SW2-1,2
- image size, using SW2-5 through 8

ATTENTION



If the addressing mode, logical group number, baud rate, and image size are not the same, unpredictable operation of both 1747-ASB modules results. No 1747-ASB module errors occur.

The 1747-ASB modules in the primary and complementary chassis *do not* have to be configured to have the same:

- hold last state selection
- processor restart lockout selection
- specialty I/O mode
- I/O module keying mode
- link response selection

In addition, the 1747-ASB modules do not have to have to be controlling the same number of slots or type of chassis.

IMPORTANT

If a 1747-ASB module is configured as a primary chassis and as the last chassis, a 1747-ASB module error occurs. Only complementary chassis can be configured as last chassis. For information concerning last chassis selection, refer to page 4-19.

Primary and complementary chassis cannot have the same logical rack number. The logical rack numbers must be assigned to the primary and complementary racks as shown below:

Primary Chassis Logical Rack Number ⁽¹⁾	Complementary Chassis Logical Rack Number	
	Decimal	Octal
0	8	10 ₈
1	9	11 ₈
2	10	12 ₈
3	11	13 ₈
4	12	14 ₈
5	13	15 ₈
6	14	16 ₈
7	15	17 ₈

(1) If a 1747-ASB module is configured as a primary chassis with a logical rack number greater than 7, a 1747-ASB module error occurs.

ATTENTION



If the logical rack numbers are not properly assigned, unpredictable operation of both 1747-ASB modules results. No 1747-ASB module errors occur.

IMPORTANT

Some processors and/or scanners have configuration limitations when using complementary I/O in the addressing modes. Refer to the appropriate PLC or scanner manual for more information.

The following example illustrates how I/O modules requiring two words of the input or output image can leave unused image space.

Complementary I/O allows two chassis to overlap their input and output images, creating one image within the scanner.

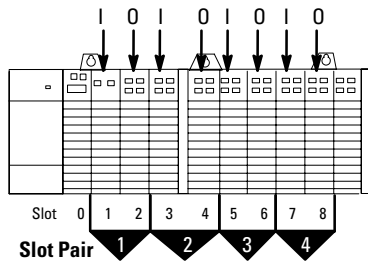

Primary Chassis

Primary Chassis Configured As:
 Logical Rack Number 0
 Logical Group Number 0
 Image Size (logical groups) 16
 Addressing Mode 1/2-slot
 Primary/Complementary Primary

I = Input Module
 O = Output Module

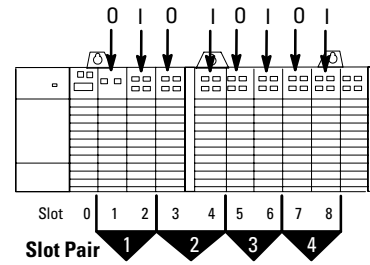

Complementary Chassis

Complementary Chassis Configured As:
 Logical Rack Number 8 (decimal)
 Logical Group Number 0
 Image Size (logical groups) 16
 Addressing Mode 1/2-slot
 Primary/Complementary Complementary

Primary Chassis I/O Image

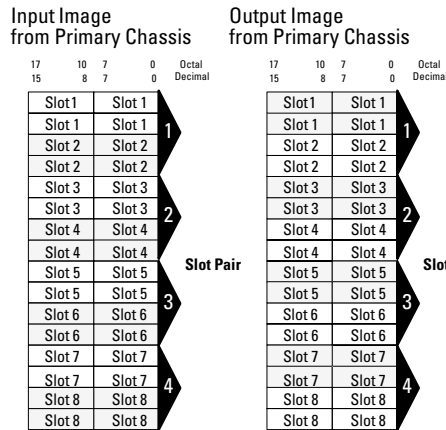

Complementary Chassis I/O Image

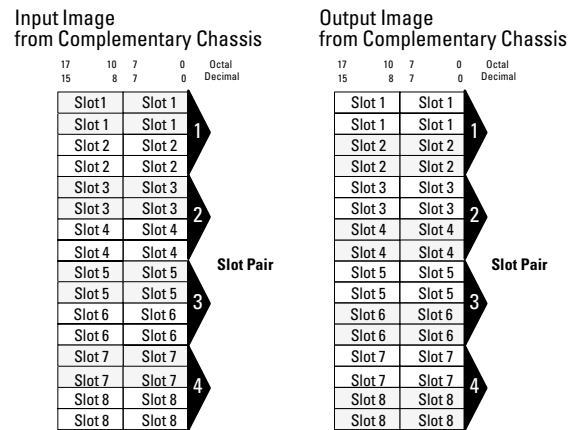

□ = unused image space

Scanner's I/O Image

Both images are overlapped in the scanner. The overlapped image appears where the primary chassis image is configured to reside.

In this case, the primary chassis image is configured as starting logical rack 0 and starting logical group 0.

Logical Rack 0

Logical Rack 1

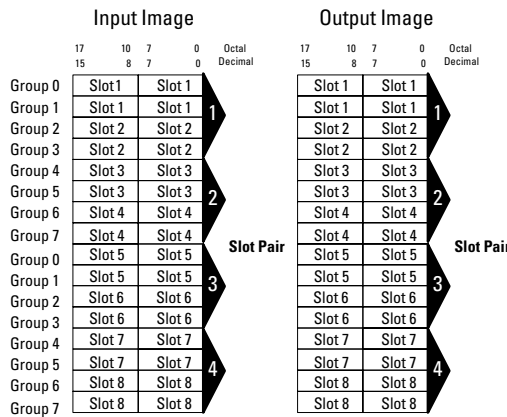

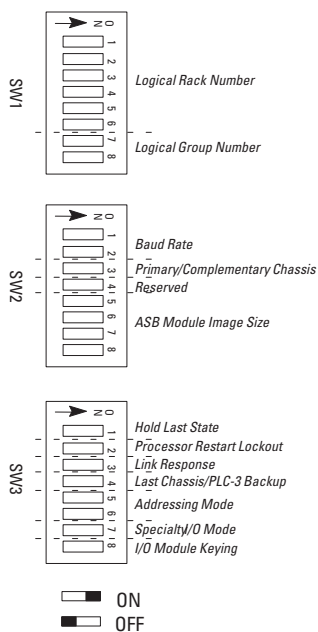

Reserved (SW2-4)

SW2 switch 4 *must* remain in the ON position.

Reserved DIP Switch Setting

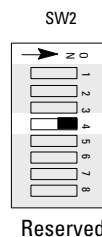

ASB Module Image Size (SW2-5, 6, 7, 8)

SW2 switches 5 through 8 determine the size of the 1747-ASB module's image that is reserved in the scanner.

You must also make sure you do not exceed the maximum logical rack number, described on page 4-11.

Image size selection examples are found on page 4-12.

Examples of odd size chassis/images are provided, starting on page 4-13.

The 1747-ASB module image size can be between 2 and 32 logical groups, in 2 logical group increments.

ASB Module Image Size DIP Switch Settings

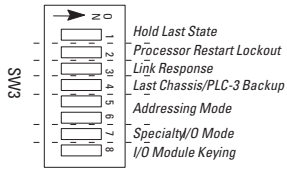
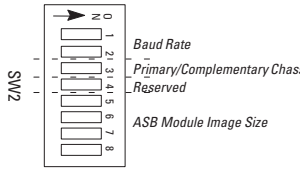
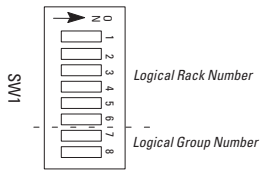

ON
OFF

Number of Logical Groups

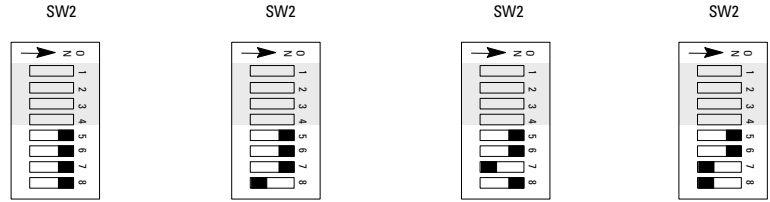

2

4

6

8

Number of Logical Groups

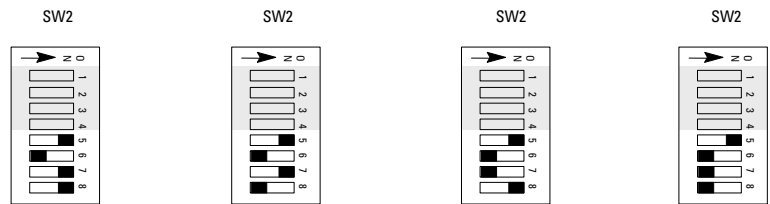

10

12

14

16

Number of Logical Groups

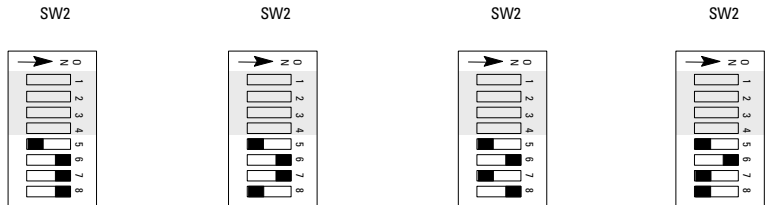

18

20

22

24

Number of Logical Groups

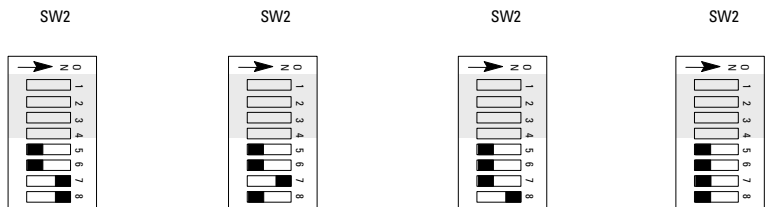

26

28

30

32

IMPORTANT

If after assigning your 1747-ASB module image size, you exceed logical rack 62 in complementary mode (SW2 switch 3) or logical rack 7 in primary mode (SW2 switch 3), an error occurs. When assigning the starting logical rack and group numbers, make sure the size of the 1747-ASB module image does not exceed the maximum logical rack number, as shown below:

Complementary Mode

	Bit Number (Octal)	17	10	7	0
	Bit Number (Decimal)	15	8	7	0
Logical Rack 59	Group 0				
	Group 1				
	Group 2				
	Group 3				
	Group 4				
	Group 5				
	Group 6				
	Group 7				
Logical Rack 60	Group 0				
	Group 1				
	Group 2				
	Group 3				
	Group 4				
	Group 5				
	Group 6				
	Group 7				
Logical Rack 61	Group 0				
	Group 1				
	Group 2				
	Group 3				
	Group 4				
	Group 5				
	Group 6				
	Group 7				
Logical Rack 62	Group 0				
	Group 1				
	Group 2				
	Group 3				
	Group 4				
	Group 5				
	Group 6				
	Group 7				

If you have selected logical rack 60, group 0 as your starting address, the largest 1747-ASB module image size you can create is 24 groups (3 logical racks). Assigning a larger 1747-ASB module image size exceeds the maximum logical rack number.

Primary Mode

	Bit Number (Octal)	17	10	7	0
	Bit Number (Decimal)	15	8	7	0
Logical Rack 4	Group 0				
	Group 1				
	Group 2				
	Group 3				
	Group 4				
	Group 5				
	Group 6				
	Group 7				
Logical Rack 5	Group 0				
	Group 1				
	Group 2				
	Group 3				
	Group 4				
	Group 5				
	Group 6				
	Group 7				
Logical Rack 6	Group 0				
	Group 1				
	Group 2				
	Group 3				
	Group 4				
	Group 5				
	Group 6				
	Group 7				
Logical Rack 7	Group 0				
	Group 1				
	Group 2				
	Group 3				
	Group 4				
	Group 5				
	Group 6				
	Group 7				

If you have selected logical rack 5, group 0 as your starting address, the largest 1747-ASB module image size you can create is 24 groups (3 logical racks). Assigning a larger 1747-ASB module image size exceeds the maximum logical rack number.

The following examples illustrate how the selection of the 1747-ASB image size is determined by:

- the addressing mode (2-slot, 1-slot, 1/2-slot)
- the number of chassis slots required

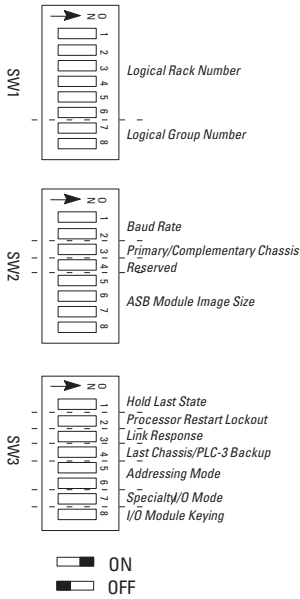

1-Slot Addressing With Six Slots Available

Using 1-slot addressing and a 7-slot chassis, six slots are available for I/O modules. To map all six slots into the scanner image, the 1747-ASB module image size must be 6 logical groups.

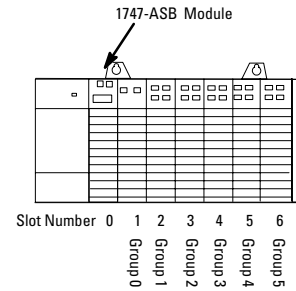

1/2-Slot Addressing With Ten Slots Available

Using 1/2-slot addressing and a 4-slot chassis attached to a 7-slot chassis, ten slots are available for I/O modules. To map all ten slots into the scanner image, the 1747-ASB module image size must be 20 logical groups.

If an image size of 16 logical groups is chosen, slots 9 and 10 are unused. If an I/O module is installed in slots 9 or 10, the 1747-ASB module ignores it unless the I/O module faults.

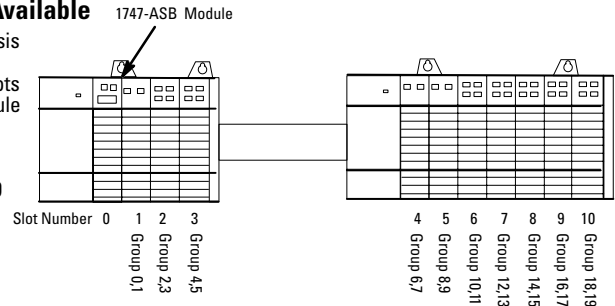

2-Slot Addressing With Nine Slots Available

Using 2-slot addressing and a 10-slot chassis, nine slots are available for I/O modules.

4 Logical Groups

Selecting 4 logical groups leaves slot 9 unused. If an I/O module is in slot 9, the 1747-ASB module ignores it, unless the I/O module faults.

Selecting 6 logical groups leaves an unused logical group in the 1747-ASB module image. The image normally assigned to slot 10 can be used by slot 9 (providing one full word).

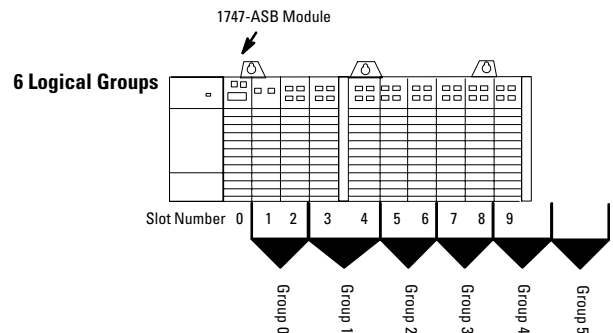
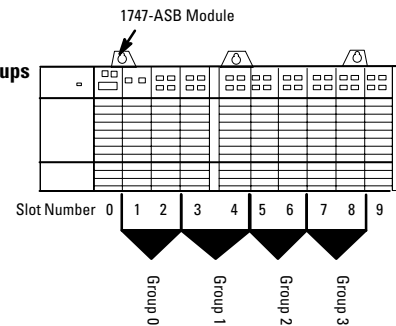

Special Image and Chassis Size Considerations

Sometimes, logical slots and groups are not mapped due to chassis size and selected image size because:

- There is not enough 1747-ASB module image to map all of the available slots.
- The 1747-ASB image size exceeds requirements for available slots.
- One slot of a pair is present, with 1747-ASB module image available for both slots.
- Both slots of a pair are available, but there is only enough 1747-ASB module image space available for one slot.

Not Enough 1747-ASB Module Image to Map All of the Available Slots

When there is not enough 1747-ASB module image to map all of the available slots, any I/O modules in the unassigned slots are ignored. If one of the unassigned I/O modules faults, it triggers a 1747-ASB module fault.

Modules should not be installed above slot 30. Otherwise a 1747-ASB error occurs.

In the following example, a 7-slot chassis contains a 1747-ASB module with an image size of 4 logical groups using 1-slot addressing.

Using 1-slot addressing and a 7-slot chassis, six slots are available for I/O modules. Because the image size is 4 logical groups, 2 slots are not used. Slots 5 and 6 are ignored, even if I/O modules are installed in them. However, if one of the modules in slots 5 or 6 faults, a 1747-ASB module error occurs.

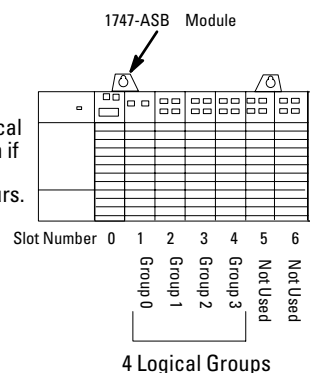

1747-ASB Image Size Exceeds Slot Requirements

When there are not enough slots available to use the entire 1747-ASB module image, output image data received by the 1747-ASB module for the extra slots is ignored. All input image data sent to the scanner for the extra slots is zero.

Using 1-slot addressing and a 7-slot chassis, six slots are available for I/O modules. Because the image size is 8 logical groups, 2 logical groups are not used. When there are not enough slots available to use the entire 1747-ASB module for the extra slots is ignored. All input image data sent to the scanner for the extra slots is zero.

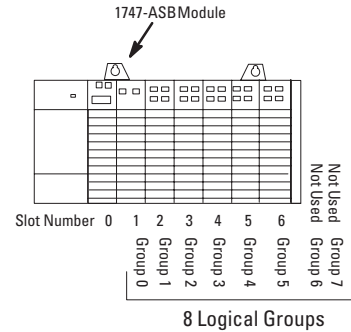

One Slot of Pair is Present, and 1747-ASB Module Image is Available for Both Slots

When one slot of a pair is present and 1747-ASB module image is available for both slots, the single slot can use the extra image space.

Using 1-slot addressing and a 4-slot chassis, three slots are available for I/O modules. Because the image size is 4 logical groups, 1 logical group is not assigned to a slot. Since slot 4 is not present, the module in slot 3 can use both logical groups assigned to the slot pair. This could be done by installing a 32-point input module in slot 3.

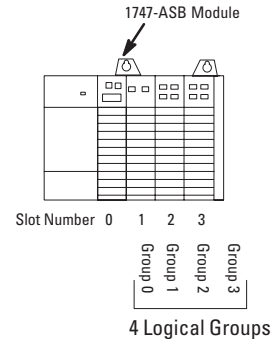

Both Slots Of A Pair Are Available But There Is Only Enough 1747-ASB Module Image Space Available For One Slot

This condition only occurs in 1/2-slot addressing.

When both slots of a pair are available but there is only enough 1747-ASB module image space available for one slot, the lower numbered slot uses the available image space. If a four word specialty module (i.e., 1746-NI4) is installed in this slot and the 1747-ASB module is configured for the discrete specialty mode, a 1747-ASB error occurs.

Using 1/2-slot addressing and a 7-slot chassis, six slots are available for I/O modules. Because the image size is 6 logical groups, the last two logical groups of the image can only be used by slot 3 (slots 4, 5, and 6 are ignored unless the module faults).

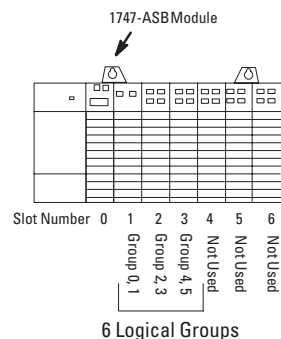

DIP Switch SW3

Hold Last State (SW3-1)

SW3 switch 1 allows discrete outputs to remain in their last state when certain, but not all, system faults occur.

Hold Last State DIP Switch Settings

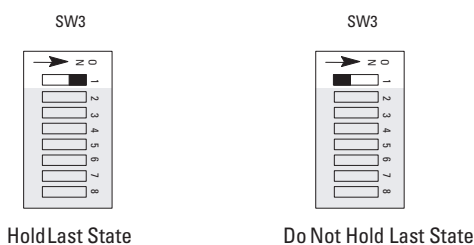

ATTENTION



If switch 1 is set to the ON position, outputs connected to this chassis remain in their last state when a fault occurs and machine motion may continue after fault detection. We recommend that you set switch 1 to the OFF position to de-energize outputs wired to this chassis when a fault is detected.

When hold last state is selected, outputs are held in their last state when any of the following conditions occur:

- RIO link communications is lost due to a broken cable or scanner fault.
- The 1747-ASB module is inhibited by the scanner.
- The 1747-ASB module receives reset, adapter decide commands from the scanner.

When the discrete outputs are being held in their last state, consider the following:

- The specialty modules operate as if they are being controlled by an SLC processor that is in the test mode. See the specialty I/O module's manual to determine the response to this condition.
- The specialty I/O module's inputs are still read by the 1747-ASB module. However, the specialty I/O module's outputs are not modified by the 1747-ASB module.

Your system must be designed so it is in a safe state when all discrete outputs are off, or cleared.

The 1747-ASB module is shipped from the factory with the hold last state switch in the OFF position (do not hold last state).

ATTENTION



When hold last state is selected and specialty I/O modules are being used, the operation of the specialty I/O modules must be considered when the discrete outputs are being held in their last state.

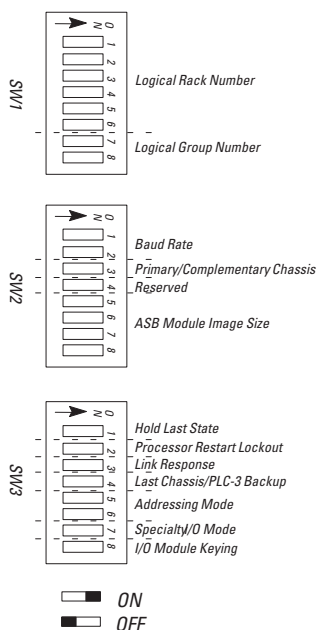

Processor Restart Lockout (SW3-2)

SW3 switch 2 determines whether your system automatically resumes RIO link communications with the scanner when:

- Link communications are temporarily interrupted. For example, by removing and replacing the RIO connector.
- The 1747-ASB module is inhibited and re-enabled.

Processor Restart Lockout DIP Switch Settings



While in the OFF position (lock processor out) and communications are restored, the 1747-ASB module does not respond to any communication commands until 1747-ASB module terminals IN and RET are momentarily shorted together. Processor restart lockout prevents RIO link communications (by locking out the scanner and processor) and does not allow the 1747-ASB module to exchange any I/O data or respond to any RIO commands, such as reset adapter reset commands.

RIO link communications can be restarted by:

- momentarily shorting pins 5 and 6 together (See chapter 5 for wiring information.)
- cycling power on any chassis controlled by the 1747-ASB module

While in the ON position, the 1747-ASB module always attempts to restart communications with the scanner if RIO link communications are interrupted or if the 1747-ASB module is inhibited and re-enabled.

While in the ON position, the 1747-ASB module does not respond if terminals 5 and 6 are shorted together.

The 1747-ASB module is shipped from the factory with the default position ON (automatic restart).

ATTENTION

Cycling power on any chassis removes the processor restart lockout condition.



IMPORTANT

After communications to all of the 1747-ASB module's logical devices are established, selecting processor restart lockout disables PLC auto configurations on the 1747-ASB module.

If the 1747-ASB module has not received communications for all of its logical devices, you are able to perform PLC auto configurations once the 1747-ASB module is powered up. If processor restart lockout is *not* selected, you are able to perform PLC auto configurations on the 1747-ASB module.

IMPORTANT

Selecting processor restart lockout affects the 1747-ASB module inhibit functionality.

Link Response Time (SW3-3)

SW3 switch 3 allows you to select a longer (restricted) response time when communicating at 57.6K and 115.2K baud. 230.4K baud operates with a short (unrestricted) response time, regardless of the switch setting.

The link response time is the time it takes an adapter to respond to data received from the scanner. Some scanners require a longer response time than other scanners. Operating unrestricted reduces overall RIO scan time, but requires a faster scanner.

Link Response Time DIP Switch Setting

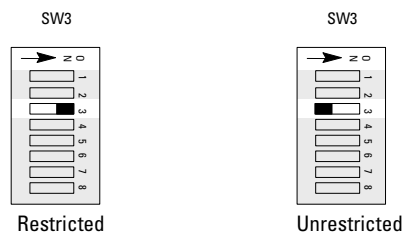

The 1747-ASB module is shipped from the factory with the default position ON (restricted).

Last Chassis

SW3 switch 4 is used for last chassis selection when the 1747-ASB module is connected to a PLC-2, PLC-5, or SLC scanner (Catalog Number 1747-SN)..

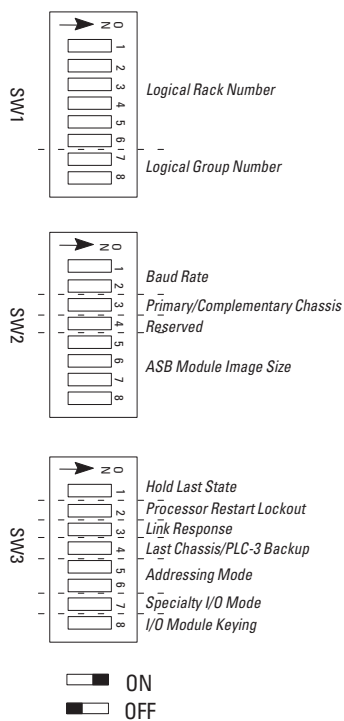

The 1747-ASB module is shipped from the factory with the default position ON (not last chassis).

A 1747-ASB module should be configured as the last chassis when:

- Its image crosses logical rack boundaries and no other adapter uses a higher group number within its last logical rack.
- It uses a portion of a logical rack and no other adapter uses a higher group number within that logical rack.

The following examples illustrate last chassis conditions.

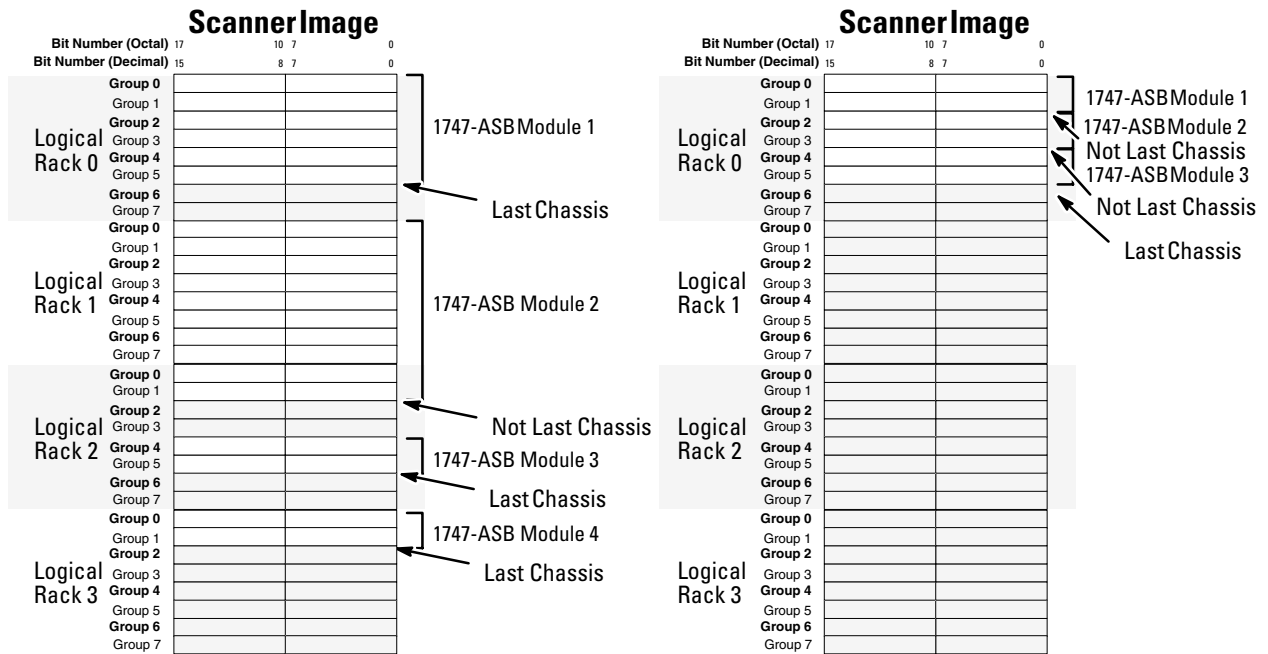

IMPORTANT

When using complementary I/O, do not configure a primary chassis as the last chassis, otherwise a 1747-ASB module error occurs.

Addressing Mode (SW3-5,6)

SW3 switches 5 and 6 determine the addressing mode of 2-slot, 1-slot, or 1/2-slot.

Addressing Mode DIP Switch Settings

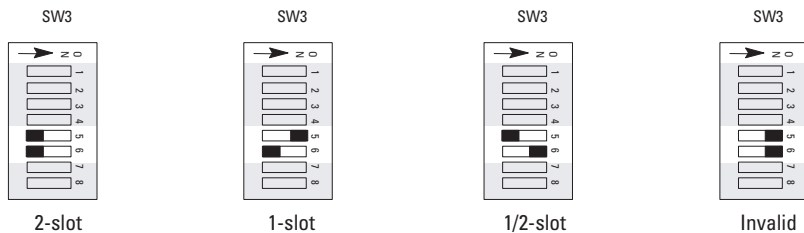

The 1747-ASB module is shipped from the factory with the default position selected for 1-slot addressing.

If the invalid switch setting is selected, a 1747-ASB module error occurs.

1/2-slot addressing is not supported by the PLC-2 family of processors.

Specialty I/O Mode (SW3-7)

SW3 switch 7 determines the specialty I/O mode (discrete or block transfer).

Specialty I/O Mode DIP Switch Settings

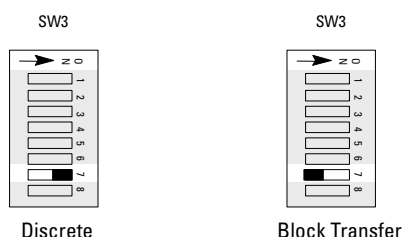

The 1747-ASB module is shipped from the factory with the default position ON (discrete).

For an overview of discrete and block transfer modes, refer to page 3-13.

I/O Module Keying (SW3-8)

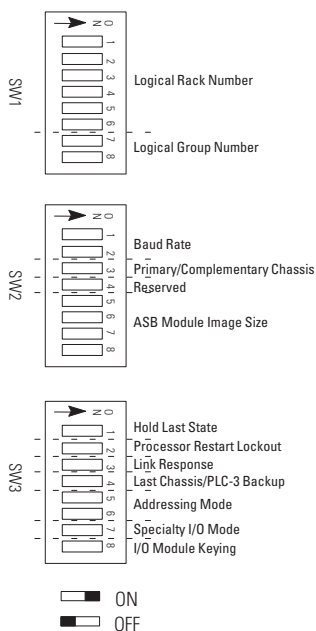

SW3 switch 8 provides I/O module keying, that prevents you from operating the 1747-ASB module when the I/O module or DIP switch configuration (other than the keying DIP switch itself) differs from the last time you saved it. There are two modes, save and check.

When power is applied in save mode and the DIP switch and I/O module configurations are valid, the 1747-ASB module saves the DIP switch and I/O module configuration in non-volatile memory.

When power is applied in check mode, the 1747-ASB module compares the stored DIP switch and I/O module configuration to the current DIP switch and I/O module configuration. If the configurations do not match, a 1747-ASB module error occurs.

IMPORTANT

Use save mode during setup and debug. After debugging is complete, power up in save mode one last time. Remove power and place the 1747-ASB module in check mode prior to normal operation.

I/O Module Keying DIP Switch Settings

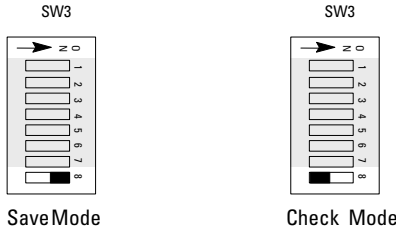

The 1747-ASB module is shipped from the factory with the default position ON (save mode).

Switch Setting Summary

The following is a summary listing the various DIP switch settings.

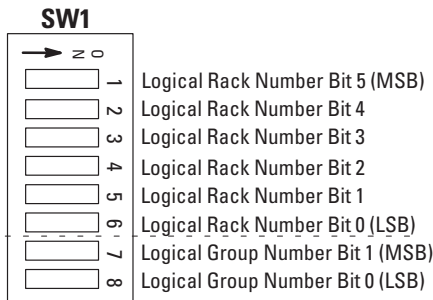

SW1

- Logical Rack Number
For details, see page 4-2.
- Logical Group Number

7	8	Group
ON	ON	0 (default)
ON	OFF	2
OFF	ON	4
OFF	OFF	6

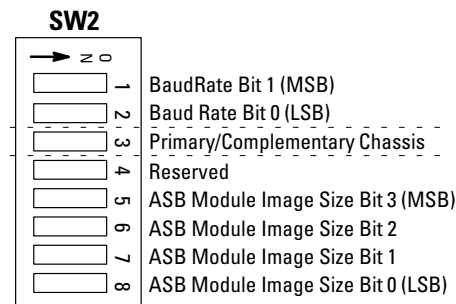

SW2

- Baud Rate
- Primary/Complementary Chassis
ON=Primary
OFF=Complementary (default)
- 1747-ASB Module Image Size
For details, see page 4-9.

SW3

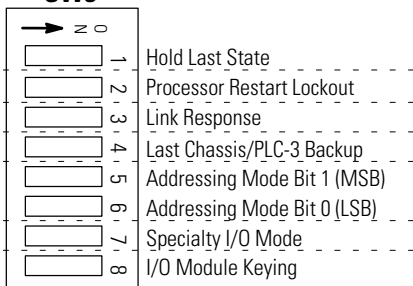

SW3

- Hold Last State
ON=Hold Last State
OFF=Do Not HOId Last State (default)
- Processor Restart Lockout
ON=Automatic Restart (default)
OFF=Processor Lockout
- Link Response
ON=Restricted (default)
OFF=Unrestricted
- Last Chassis
ON=Not Last Chassis (default)
OFF=Last Chassis
- Addressing Mode

5	6	Address
ON	ON	Invalid
ON	OFF	1-slot Addressing (default)
OFF	ON	1/2-slot Addressing
OFF	OFF	2-slot Addressing

Installation and Wiring

This chapter presents installation and wiring information for the remote I/O adapter module.

If this product is installed within the European Union or EEA regions and has the CE mark, the following regulations apply.

European Union Direct Compliance

EMC Directive

This apparatus is tested to meet Council Directive 89/336 Electromagnetic Compatibility (EMC) using a technical construction file and the following standards, in whole or in part:

- EN 50081-2 EMC - Generic Emission Standard, Part 2 - Industrial Environment
- EN 50082-2 EMC - Generic Immunity Standard, Part 2 - Industrial Environment

The product described in this manual is intended for use in an industrial environment.

Installing the 1747-ASB Module

ATTENTION

Disconnect power before attempting to install or remove the module.



-
1. Install the module in slot 0 of the remote chassis by aligning the circuit board with the chassis card guide.
The 1747-ASB module must only be installed in slot 0 (the left slot) of the remote chassis. Do not install the 1747-ASB module in the remote expansion chassis.

2. Slide the module into the chassis until the top and bottom tabs lock into place. To remove the module, press and hold the release located on each self-locking tab and slide the module out.
3. Cover all unused slots with the Card Slot Filler, Catalog Number 1746-N2.

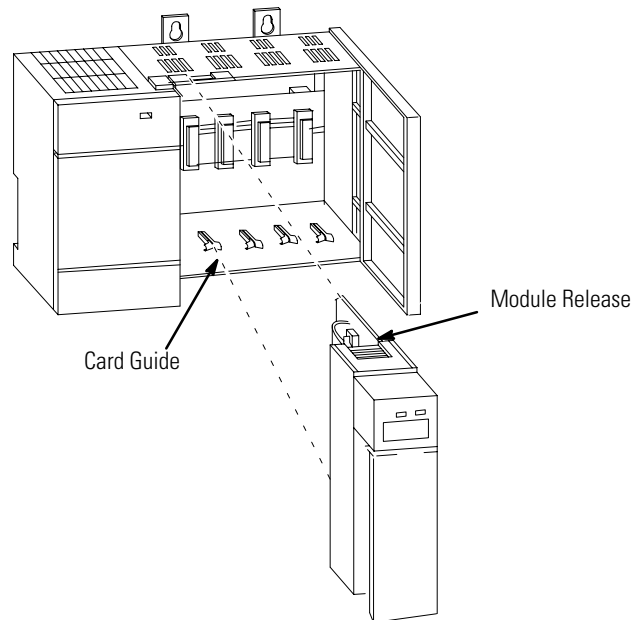

The modules are connected in a daisy chain configuration on any RIO link. A daisy chain network is formed by connecting network devices together in a serial manner using Belden 9463 cable. Belden 9463 cable is the only approved cable for Allen-Bradley RIO links.

Link Wiring

The total number of adapters allowed on the RIO link are:

- 32 if the scanner and *all* adapters on the RIO link have extended node capability
- 16 if the scanner or any adapter does not have extended node capability

Refer to page 1-8 for information on extended node capability.

There are no restrictions governing the spacing between the devices, as long as the maximum cable distance is not exceeded. Refer to the table below for baud rate and maximum cable distances.

Baud Rate	Maximum Cable Distance
57.6K baud	3048 meters (10,000 feet)
115.2K baud	1525 meters (5,000 feet)
230.4K baud	750 meters (2,500 feet)

IMPORTANT

No two devices can be connected to the same point on the link. An example of correct and incorrect link wiring is shown below.

Correct Link Wiring

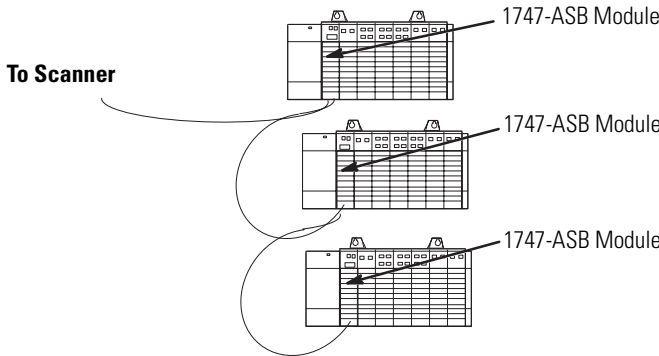

Incorrect Link Wiring

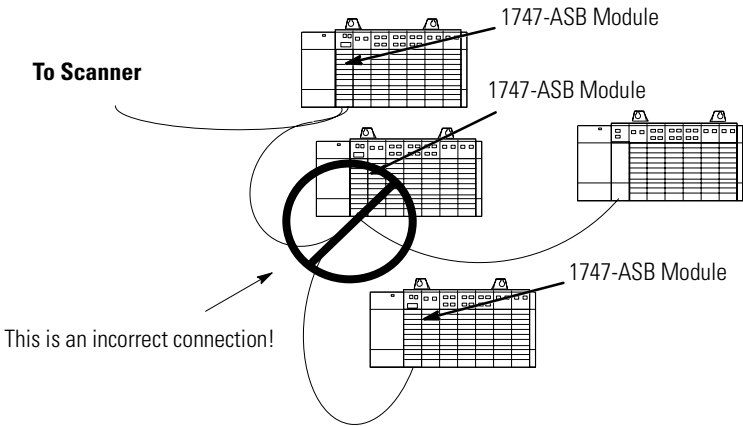

Link Termination

A 6-pin keyed connector provides a quick connection to the RIO link and processor restart lockout switch. A user-supplied terminating resistor must be attached across line one and two of the connector at each end of the RIO link. The Ω size of the resistor depends on the baud rate and whether the scanner and all adapters have extended node capability, as shown in the table below. The cable shield must be connected to chassis ground *only* at one end of the RIO link.

Baud Rate		Terminating Resistor Size
Using Extended Node Capability	All Baud Rates	82 Ω 1/2 Watt
	57.6K baud	150 Ω 1/2 Watt
Not Using Extended Node Capability	115.2K baud	150 Ω 1/2 Watt
	230.4K baud	82 Ω 1/2 Watt

IMPORTANT

If the signal integrity on the RIO link is compromised by environmental noise, improper termination, and/or improper cable installation, the 1747-ASB module scan rate drops. This is indicated by a pronounced flickering of the status display.

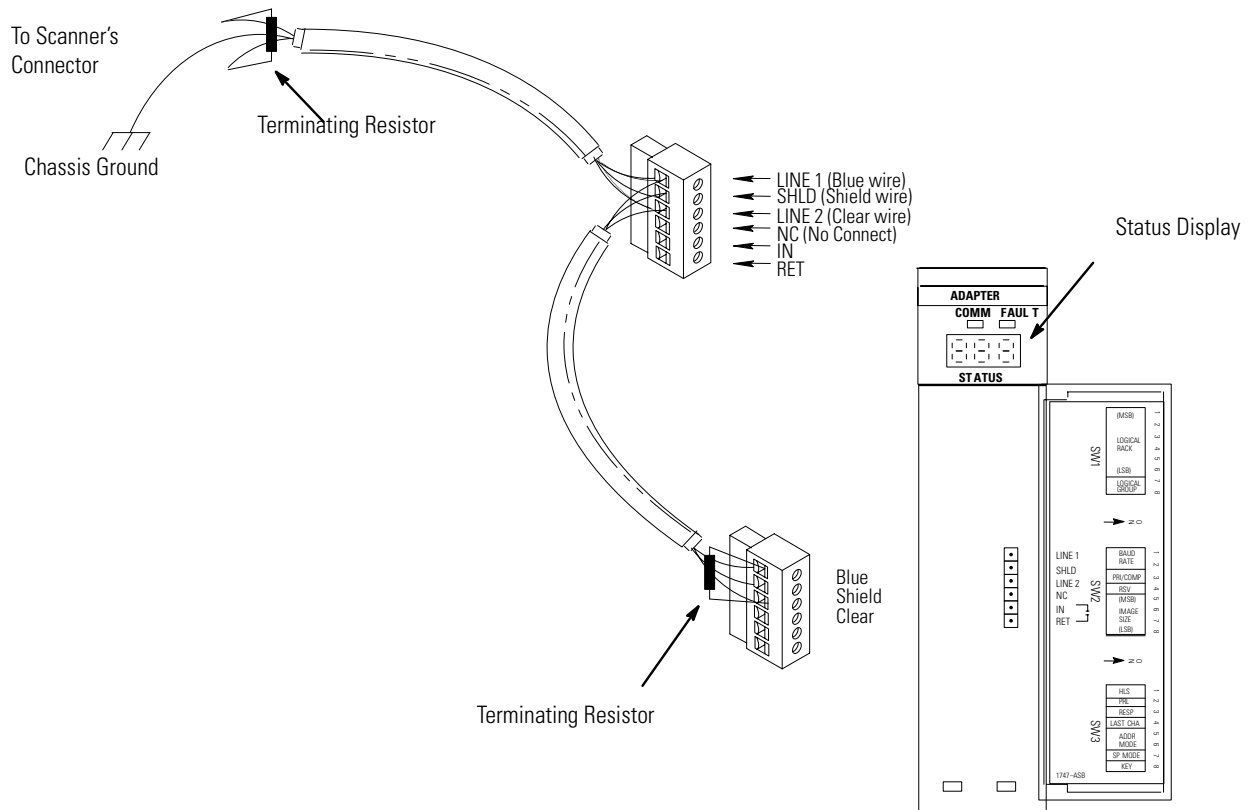

IMPORTANT

Do not connect anything to the NC (No Connect) terminal.

Wiring a Processor Restart Lockout Switch

When processor restart lockout is enabled (SW3-2) and communications are restored, the 1747-ASB module does *not* respond to any type of communications, or communication commands until terminals IN and RET are momentarily shorted together. This occurs while the RIO scanner is attempting to communicate with the 1747-ASB module.

ATTENTION



Cycling power on any 1747-ASB module chassis removes the processor restart lockout condition by re-initializing the 1747-ASB module.

You must use a momentary switch (Class 1, Division 2) to short the terminals together. The processor restart lockout is removed as soon as the switch toggles back to the open circuit position.

A maximum of five feet of 14-24 gauge wire (solid or stranded) is recommended to connect the switch to the terminal.

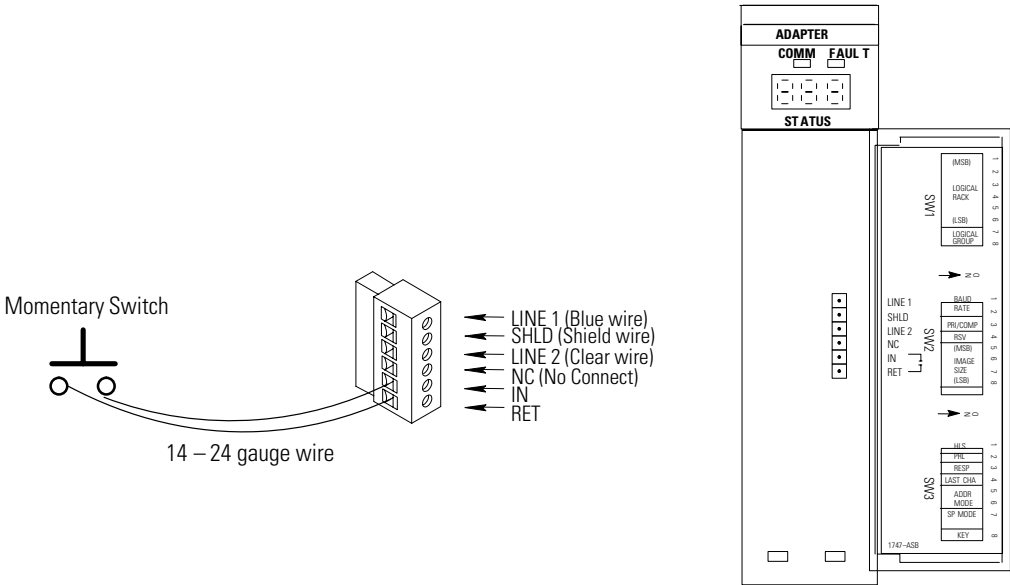

IMPORTANT

Do not connect anything to the NC (No Connect) terminal.

Due to the 1747-ASB module's addressing modes and RIO link operation, the I/O modules controlled by the 1747-ASB module are addressed by the PLC processor on a logical rack, logical group basis and by the SLC processor on a 1747-SN scanner slot and word basis. A remote PLC and SLC label kit is included with each 1747-ASB module to assist you in addressing your I/O modules.

I/O Module Addressing Labels

Use the labels that correspond to the type of master you are using (PLC or SLC). Attach the Remote PLC or SLC label to the outside bottom of *each* I/O module in your 1747-ASB chassis. Fill out each label completely. RIO address label examples are provided on pages 8-5 and 8-13 (SLC), and 8-23 (PLC).

IMPORTANT

When the 1747-ASB module is used with PLC processors, use octal labels with discrete 1746 I/O modules that have 16 or more points. (See page 5-7.)

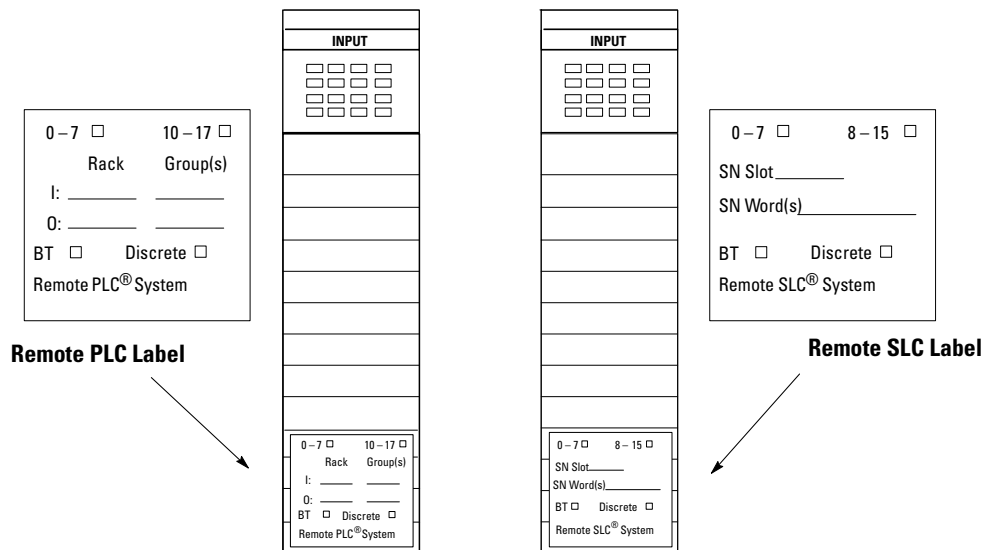

Using a PLC as a Master

If you are using a PLC processor as a master, each I/O module is addressed by logical rack and logical group, regardless of what physical slot it is in.

Using an SLC as a Master

If you are using an SLC processor as a master, each I/O module is addressed by the physical slot number of the 1747-SN scanner and the word that the I/O module uses in the scanner image. Data is transferred on the network by logical rack and logical group number.

Octal Label Kit Installation

The octal filter and door label *must* be used when working with a PLC processor as a master. An octal label kit is included with the I/O modules listed in the table on page 5-8. The kits can also be obtained through your Rockwell Automation distributor.

Applying the Octal Filter Label

1. Remove the octal filter label from its paper carrier.
2. Align the octal filter label numbers horizontally to the module color bar and over the decimal filter numbers, as shown in the illustration below.
3. Apply the octal label to the filter.
4. Press firmly to ensure proper adhesion of the label.

Applying the Octal Door Label

1. Remove the octal door label from its paper carrier.
2. Align it over the decimal door label on the inside of the door.
3. Press firmly to ensure proper adhesion of the label.

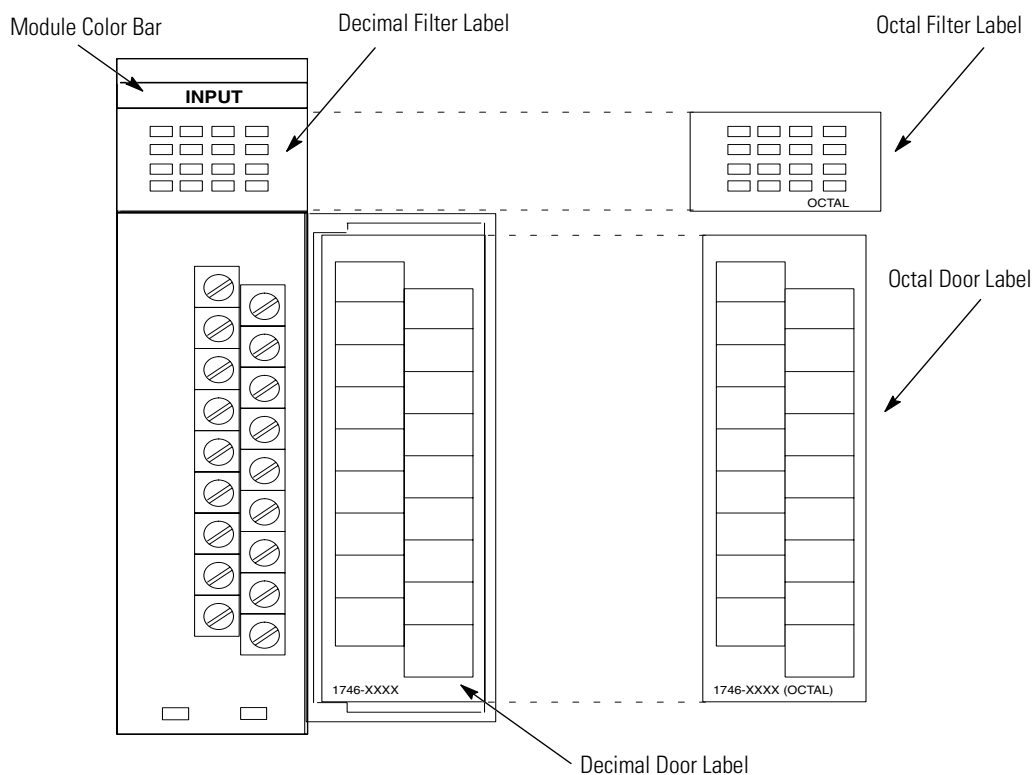

Octal Kit and I/O Module Information

Octal Kit Catalog Number 1746-	Applies to I/O Module 1746-⁽¹⁾
RL40	IA16
RL41	IB16
RL42	IG16
RL43	IM16
RL44	IN16
RL45	IV16
RL46	ITB16
RL47	ITV16
RL50	OA16
RL51	OB16
RL52	OG16
RL53	OV16
RL54	OW16
RL55	OBP16
RL56	OVP16
RL57	OAP12
RL58	IC16
RL59	IH16
RL60	IB32
RL61	IV32
RL70	OB32 (E)
RL71	OV32
RL72	OB16E

(1) Kit available with series C I/O modules.

Start-Up and Operation

This chapter guides you through:

- system start-up
- powerup and initialization sequences
- initial link communications
- normal operation
- communication exceptions
- remote expansion chassis power loss
- invalid RIO link transfers
- testing the 1747-ASB module

Make sure SW3-8 is ON (save mode) while you setup and debug your system. When you have completed debugging your system:

System Start-Up

1. Cycle the power one last time in save mode (SW3-8 ON).
2. Remove power from the system.
3. Remove the 1747-ASB module and set SW3-8 to the OFF position (check mode).
4. Replace the 1747-ASB module in slot 0.
5. Apply power to your system.

Any future changes to the 1747-ASB module's DIP switch or I/O module configuration results in a 1747-ASB module error, as long as the 1747-ASB module is in check mode.

The powerup and initialization sequence depends on whether the 1747-ASB module is in the save or check mode (SW3-8). RIO communications do not commence until a powerup and initialization sequence is complete.

Powerup and Initialization Sequences

Power must be applied to all of the remote chassis and remote expansion chassis controlled by the 1747-ASB module before this sequence can be completed. If the remote expansion chassis are not powered, a 1747-ASB module error occurs.

Save Mode

When power is applied in *save mode*, the 1747-ASB module:

1. Performs power up diagnostics
2. Reads and verifies the actual DIP switch and I/O module configuration
3. Saves the DIP switch and I/O module configuration
4. Waits for RIO link communications from the scanner

Check Mode

When power is applied in *check mode*, the 1747-ASB module:

1. Performs power up diagnostics
2. Verifies the stored configuration integrity
3. Compares the actual DIP switch, I/O module and chassis configurations to the stored configurations
4. Waits for RIO link communications from the scanner

1747-ASB module errors found during powerup and initialization are noted in chapter 7.

After successfully completing a powerup and initialization sequence, the 1747-ASB module waits to receive RIO link communications from the scanner for all of its logical devices. Once the 1747-ASB module receives RIO link communication for all of its logical devices, it begins normal operation.

Normal Operation

During normal operation (PLC or SLC in Run mode), the 1747-ASB module appears as shown below:

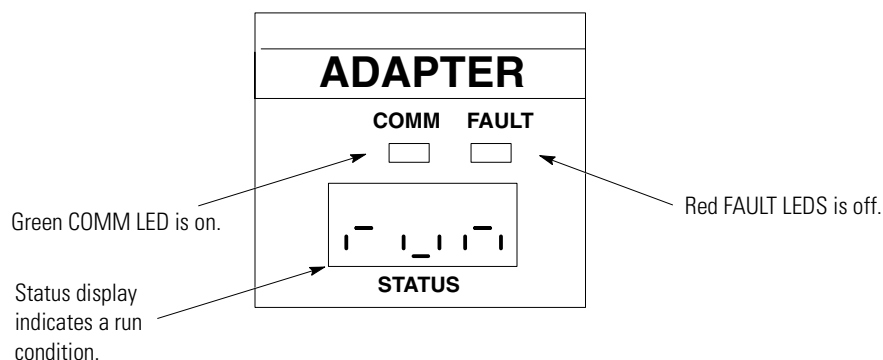

A communication exception is not an error because once the exception is corrected, the 1747-ASB module begins normal operation without the need to cycle remote chassis or remote expansion chassis power. Communication exceptions are conditions that prevent normal RIO link communications. They may even be purposely used to change the operating state of the 1747-ASB module.

Communication Exception

If a communication exception exists with one logical device under the 1747-ASB module's control, the 1747-ASB module treats all logical devices under its control as if they too have the same condition. For example, if one logical device is inhibited, the 1747-ASB module treats all of its logical devices as if they too were inhibited.

Communication exceptions can only occur after the 1747-ASB module has first received communications from the scanner for all of its logical devices.

If the 1747-ASB module is more than one logical device, more than one communication exception may be present at the same time. If this occurs, they are handled on a priority basis.

Priority	Condition
1	Loss of RIO link communications
2	Inhibits
3	Reset, adapter reset commands
4	Reset, adapter decide commands

Therefore, if one of the 1747-ASB module's logical devices is receiving reset adapter decide commands and another is inhibited, the 1747-ASB module treats all of its logical devices under its control as if they too were inhibited. Once the inhibit condition is cleared, the module treats all of its logical devices as if they were receiving reset adapter decide commands.

Inhibit Condition

When any of the 1747-ASB module's logical devices are inhibited before communication with all of its logical devices occur at least once:

- The inhibited logical devices do not communicate on the RIO link.
- The enabled logical devices communicate on the RIO link.
- The 1747-ASB module does not send output data to any of its output modules, even those that are enabled.
- The 1747-ASB module does not process any RIO block transfer writes.
- The 1747-ASB module sends new input data from its input modules to the scanner for enabled devices.
- The 1747-ASB module processes RIO block transfers reads for enabled devices.

The position of the processor restart lockout switch (PRL) affects the 1747-ASB module's inhibit functionality. If processor restart lockout is *selected*, and any logical device assigned to the 1747-ASB module is inhibited after all of the logical devices have received RIO link communications from the scanner at least once:

- All of the 1747-ASB module's logical devices stop communicating on the RIO link.
- The 1747-ASB module does not send any output data to any of its output modules.
- Discrete outputs are held in their last state if hold last state is selected, or discrete outputs are reset if hold last state is not selected.
- The 1747-ASB module does not process any RIO block transfers.

If processor restart lockout is *not selected* and any logical device assigned to the 1747-ASB module is inhibited after all of the logical devices have received RIO link communications from the scanner at least once:

- The inhibited logical devices stop communicating on the RIO link.
- The enabled logical devices continue to communicate on the RIO link.
- The 1747-ASB module does not send new output data to any logical device output module, even those that are enabled.

- Discrete outputs are held in their last state if hold last state is selected, or discrete outputs are reset if hold last state is not selected.
- The 1747-ASB module does not process any RIO block transfer writes.
- The 1747-ASB module sends new input data from its input modules to the scanner for enabled logical devices.
- The 1747-ASB module processes RIO block transfer reads for enabled logical devices.

IMPORTANT

Reset, adapter reset and reset, adapter decide commands are always ignored by the 1747-ASB module when any of its logical devices are inhibited.

See page 7-2 for information regarding status codes.

The following table provides specific information concerning how the inputs and outputs are handled during normal operation and when communication exceptions occur. Notice that the hold last state setting makes a difference in the control of the discrete outputs and how the specialty I/O modules may operate.

1747-ASB Condition	Specialty I/O Module		Discrete Outputs	All Inputs
	Outputs	SLC State ⁽¹⁾		
Waiting for communications after powerup	Not updated	Test	Cleared	Read
Normal running	Changing	Run	Changing	Read
Hold last state selected ⁽²⁾	1747-ASB module inhibited	Not updated		Read
	Loss of communications			
	Reset adapter decide			
Hold last state selected or not selected ⁽³⁾	1747-ASB module inhibited	Not updated	Test	Cleared
	Loss of communications			
	Reset adapter decide	Updated		Read
Reset adapter reset commands received	Updated	Test	Cleared	Read
Major error ⁽⁴⁾	Not updated	Program/Fault	Cleared	Not read
Minor error ⁽⁵⁾	Not updated	Program/Fault	Cleared	Not read
Expansion chassis power loss	Not updated	Program/Fault	Cleared	Not read

(1) This is the 1747-ASB module's operating mode, as compared to an SLC processor. For example, if the SLC state is TEST, the 1747-ASB module is controlling the specialty I/O modules in the same manner as an SLC processor would in the test mode. Refer to the appropriate SLC specialty I/O user's manual for more information.

(2) After the 1747-ASB module enters the Run mode.

(3) Before the 1747-ASB module enters the Run mode.

(4) This type of error is usually associated with the 1747-ASB module. Refer to Chapter 7 for more information.

(5) This type of error is usually associated with a configuration error. Refer to Chapter 7 for more information.

Remote Expansion Chassis Power Loss

If power to any remote expansion chassis is lost, a 1747-ASB module error occurs. When power to the remote expansion chassis is restored, the 1747-ASB module acts as if its own chassis power was cycled and resets itself, restoring normal operation unless a major fault occurred.

The 1747-ASB module assigns each slot in the remote chassis and remote expansion chassis a fixed amount of its image using slot addressing. The 1747-ASB module then maps the I/O module's images to the portion of the 1747-ASB image that is assigned to their slots.

Invalid RIO Link Transfers

If the I/O module in any slot is block transfer mapped, the 1747-ASB module expects data for that I/O module to be transferred on the RIO link using RIO block transfers. If the I/O module in any slot is discretely mapped, the 1747-ASB expects data for that I/O module to be transferred on the RIO link using RIO discrete transfers.

An Invalid RIO link transfer occurs when the 1747-ASB module receives data for a slot in a manner other than that for which the 1747-ASB module is expecting to receive data for that slot.

Invalid RIO link transfers are categorized below. Errors are not generated by these conditions:

- RIO discrete or block transfers to empty or nonexistent slots
- RIO discrete transfers to block transfer slots
- RIO block transfers to discrete slots
- invalid length RIO block transfers

RIO Discrete or Block Transfers To Empty or Nonexistent Chassis Slots

Discrete output image data received by the 1747-ASB module or RIO block transfers to empty or nonexistent slots are ignored by the 1747-ASB module.

Discrete input image data sent by the 1747-ASB module for empty or nonexistent slots are all zeros.

RIO Discrete Transfers To Block Transfer Chassis Slots

Discrete output image data received by the 1747-ASB module for a block transfer slot is ignored by the 1747-ASB module.

Discrete input image data from the 1747-ASB module for block transfer slots may be non-zero.

RIO Block Transfers To Discrete Chassis Slots

RIO block transfers to the 1747-ASB module for discrete slots are ignored by the 1747-ASB module.

IMPORTANT

Performing an RIO block transfer to a discrete chassis slot which has an output module in it may cause outputs on that module to turn on.

Invalid Length RIO Block Transfers

An invalid length RIO block transfer occurs when:

1. An RIO block transfer to an I/O module controlled by the 1747-ASB module is larger than the I/O module's image size. For example, if an eight word RIO block transfer is made to a I/O module with an image size of four words, an invalid length RIO block transfer has occurred.
2. An RIO block transfer write is made to a slot that contains a module that only has input image.
3. An RIO block transfer read is made from a slot that contains a module that only has output image.
4. Invalid length block transfers are ignored by the 1747-ASB module.

Testing the 1747-ASB Module

The 1747-ASB module can be tested prior to beginning normal operation by following the procedure provided below:

1. Install the 1747-ASB module and I/O modules into the remote chassis, and if necessary, remote expansion chassis. Make sure the PLC or SLC processor is in the program mode.

2. Apply power to all chassis.
3. After completing power up diagnostics, the 1747-ASB module display appears as shown below:

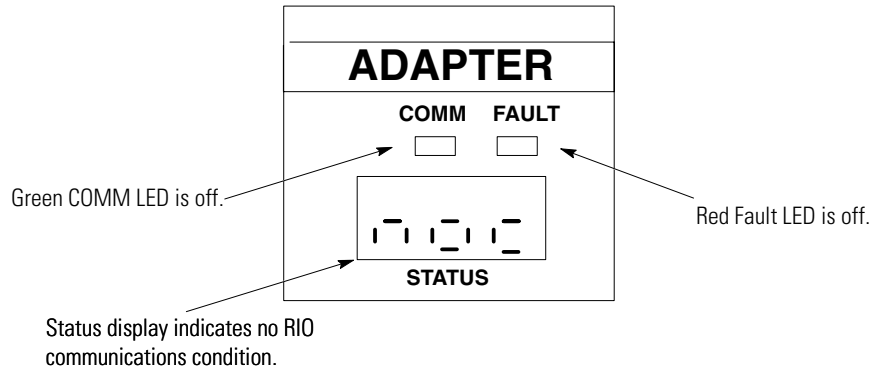

4. Configure the PLC or SLC processor so that the scanner will communicate on the RIO link with the 1747-ASB module. Place the processor in the test mode. The 1747-ASB module display appears as shown below:

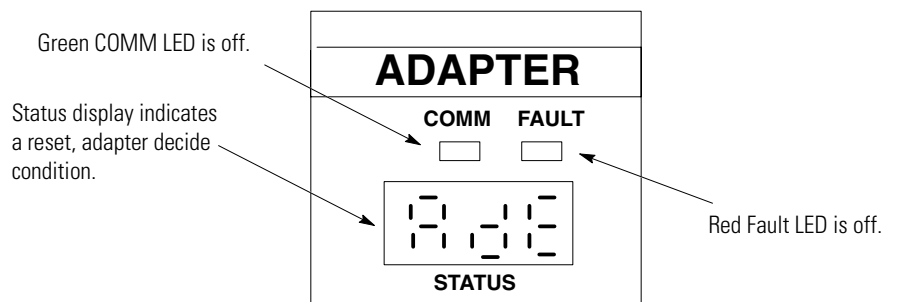
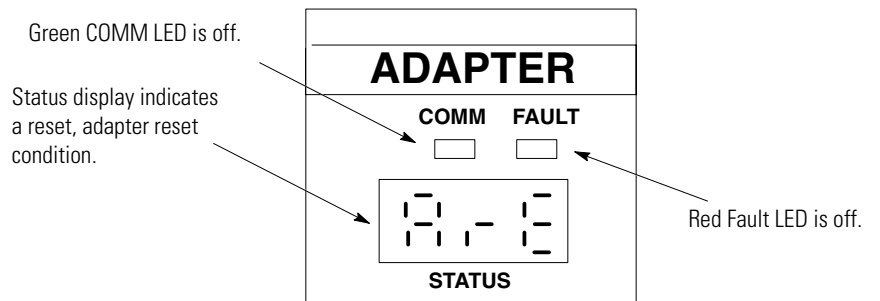

When the 1747-ASB module is receiving reset, adapter reset or reset, adapter decide commands, it:

- returns input data for all of its input modules and sends output data to all of its specialty I/O modules. It does not turn any discrete outputs on.
- processes all discrete and block transfers
- controls the specialty I/O modules in the same manner as an SLC processor in TEST mode. How each specialty I/O module responds to the TEST mode is specific to each specialty I/O module. Refer to its user manual for more information.

ATTENTION

I/O modules must *not* be inserted or removed when the remote chassis or remote expansion chassis is powered. Damage to the I/O module and/or remote chassis or remote expansion chassis may result.

The following describes how the 1747-ASB module responds if an I/O module is inserted or removed from a remote chassis or remote expansion chassis when no 1747-ASB module error is present.⁽¹⁾

I/O Module Insertion into a Slot

When an I/O module is inserted, a 1747-ASB module error occurs and all discrete outputs under its control are cleared regardless of the hold last state selection.

I/O Module Removal from a Scanned Slot

When an I/O module is removed from a slot being scanned by the 1747-ASB module, a 1747-ASB module error occurs and all discrete outputs under its control are cleared regardless of the hold last state selection.

Any I/O module that has input image and is mapped into the 1747-ASB module image, is always scanned by the 1747-ASB module.

(1) Loss of power to the remote chassis or remote expansion chassis is considered a 1747-ASB module error. I/O modules can be inserted or removed from a remote expansion chassis that is not powered, even if the remote chassis is powered. Each chassis has its own power supply.

Any discrete I/O module or discretely mapped specialty I/O module which is mapped into the 1747-ASB module image having only output image, is scanned by the 1747-ASB module unless:

- The 1747-ASB module is not receiving communications from the scanner.
- The 1747-ASB module is receiving reset, adapter decide commands and the discrete outputs are being held in their last state.

Any block transfer mapped specialty I/O module which is mapped into the 1747-ASB image having only output image, is scanned by the 1747-ASB module only when a block transfer write to the I/O module occurs.

I/O Module Removal from an Unscanned Slot

When an I/O module is removed from a slot *not* being scanned by the 1747-ASB module, a 1747-ASB error does not occur and all discrete outputs under its control are not affected.

Any I/O module not mapped into the 1747-ASB module image is never scanned by the 1747-ASB module.

Any block transfer mapped specialty I/O module which is mapped into the 1747-ASB image having only output image, is scanned by the 1747-ASB module only when a block transfer write occurs.

Troubleshooting

This chapter presents status display information during operational and fault conditions.

The 1747-ASB module has two LEDs and a status display. These LEDs and status display are used to indicate operating status and error conditions while the module is operating.

Troubleshooting Introduction

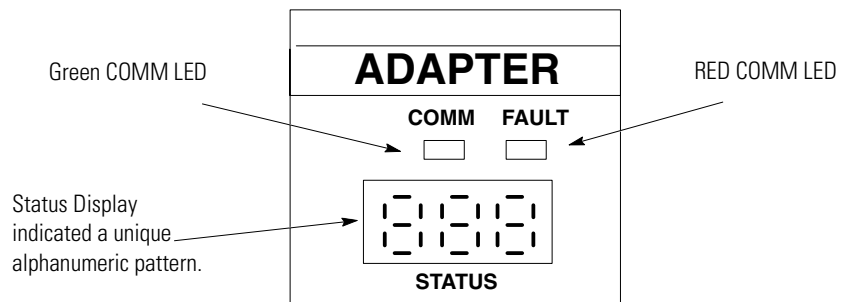

There are two types of errors: major and minor. A major error is indicated by a constant red Fault LED. This type of error is usually associated with the 1747-ASB module. A minor error is indicated by a flashing red Fault LED. This type of error is usually associated with a configuration error.

IMPORTANT

The 1747-ASB status displays are scanned one at a time at a high rate of speed by the 1747-ASB module. Visually it appears as if the displays are all on at the same time. If the status display is flickering pronouncedly, the signal integrity on the RIO link has been compromised by environmental noise, improper termination, and/or improper cable installation. This compromise results in a drop in the scan rate of the 1747-ASB module displays.

Contacting Rockwell Automation

If you need to contact Rockwell Automation for assistance, please have the following information available when you call:

- Processor type, 1747-ASB series letter, and firmware (FRN) number. See label on left side of processor and 1747-ASB module.
- LED status and error codes
- hardware types in the system including I/O modules and chassis

Status Operating Codes for Normal Operating Conditions

COMM LED	FAULT LED	Status Display	Operating Condition
on	off		Normal RIO Communications
off	off		No RIO Communications ⁽¹⁾
off	off		Partial RIO Communications ⁽²⁾
off	off		Processor Lockout is Preventing RIO Communications ⁽¹⁾⁽³⁾
flashing	off		Reset, Adapter Decide Commands ⁽¹⁾
flashing	off		Reset, Adapter Reset Commands





(1) When the 1747-ASB module is holding outputs in their last state, the Status Display alternates between the operating indication and HLS.

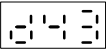

(2) Some, but not all of the 1747-ASB module's logical devices are receiving RIO link communications from the scanner. The 1747-ASB module is returning valid input data to the scanner, but is not turning outputs on or off.

(3) The 1747-ASB module is locking the processor out while it is trying to communicate with all of the 1747-ASB module's logical devices.

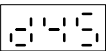
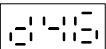
Error Codes for Error Conditions

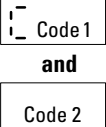
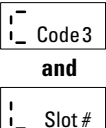
COMM LED	FAULT LED	Status Display	Error Condition	Corrective Action
off	on		Power Up Self Test in progress	This appears for less than one second after power is applied. Replace the 1747-ASB module if condition persists.
off	on		Powerup OK. 1747-ASB configuring RIO image.	This occurs for several seconds after power is applied. Replace the 1747-ASB module if condition persists.
off	on		Powerup Self Test Error (normal operating mode)	Cycle power to reset the 1747-ASB module. If the problem persists, replace the 1747-ASB module.
off	on		Runtime RAM Fault	Cycle power to reset the 1747-ASB module. If the problem persists, replace the 1747-ASB module.
off	on		Watchdog Reset Detected ⁽¹⁾	Cycle power to reset the 1747-ASB module. If the problem persists, replace the 1747-ASB module.
off	on		Configuration Store Fault (EEPROM failed write verification). The non-volatile memory is not being written correctly when powering up in Save Mode.	Cycle power to reset the 1747-ASB module. If the problem persists, replace the 1747-ASB module.
off	flashing		Remote Power Fail (expansion chassis powered down)	Apply power to all remote expansion chassis. Check remote expansion cable connections.
off	flashing		Bad Number of chassis (extra expansion chassis, 4 or more)	Remove the extra chassis.
off	flashing		Invalid Starting Group (logical group 2 or 6 selected with 1/2-slot addressing).	Select starting logical group 0 or 4 (SW1-7,8).
off	flashing		Undefined Addressing Mode	Check addressing mode selection (SW3-5,6).
off	flashing		1747-ASB Module Image Size Too Large (above 2 logical racks for 2-slot addressing)	Check image size selection (SW2-5,6,7,8). 16 logical groups is the maximum size when 2-slot addressing is selected.

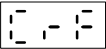
off	flashing		Illegal logical Rack Address (8 or above in primary mode or 63 in complementary mode).	Check the starting logical rack number (SW1-1,2,3,4,5,6).
off	flashing		Last Address Exceeded (image crosses into logical rack 8 in primary mode or logical rack 63 in complementary mode)	Check the starting logical rack number (SW1-1,2,3,4,5,6), starting logical group number (SW1-7,8), and image size selection (SW2-5,6,7,8).
off	flashing		Last Chassis Not Allowed (when primary mode is selected)	Check primary/complementary chassis selection (SW2-3), and the last chassis selection (SW3-4).
off	flashing		Invalid Baud Rate	Check baud rate selection (SW2-1,2).
off	flashing		I/O Module Placement Error. ⁽²⁾ The I/O module in slot# may have its image overlapping the image of the I/O module in its paired slot.	Check the addressing mode (SW3-5,6) and the I/O module type installed in this slot.
			I/O Module Placement Error. ⁽²⁾ A 32 point module may be installed in slot# and 2-slot addressing is selected.	Remove the 32 point module or change the addressing mode (SW3-5,6).
			Module in slot# has only part of its image assigned to the 1747-ASB image (1/2-slot addressing and discrete mode only).	Change 1747-ASB module image size (SW2-5,6,7,8) or specialty mode (SW3-9).
off	flashing		An Unsupported I/O Module is installed in slot#.	Remove the unsupported I/O module.
off	flashing		DIP Switch Configuration Mismatch. ⁽³⁾ The DIP switch values that were stored when the 1747-ASB module was powered up in save mode (SW3-8) do not match the current settings now that the 1747-ASB module is in check mode.	Change the incorrect switch settings, or change to Save Mode.
off	flashing		I/O Configuration Mismatch and Location. ⁽²⁾⁽⁴⁾ The I/O module configuration that was stored when the 1747-ASB module was powered up in save mode (SW3-8) does not match the configuration now that the 1747-ASB module is in check mode due to a problem with slot#.	Correct the I/O module configuration problem or change to the Save Mode.

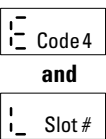
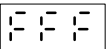

off	flashing		Configuration Read Fault (data in EEPROM not valid). The configuration stored in non-volatile memory is not valid when powering up in Check Mode.	Change to Save Mode and restore power. Change back to Check Mode and restore power.
off	flashing		Duplicate Adapter Address. There is another adapter on the RIO link that has the same RIO address as the 1747-ASB module.	Check the 1747-ASB module's starting logical rack number (SW1-1,2,3,4,5,6), and the 1747-ASB module's starting logical group number (SW1-7,8), and the 1747-ASB module's image size (SW2-5,6,7,8).
off	flashing		I/O Runtime Fault (Error, Location) ⁽²⁾⁽⁵⁾	Check the I/O module in slot#. Cycle power to the 1747-ASB module and the I/O module. If the condition persists, replace the I/O module.
on	on		Module is in test mode.	Check jumper pins on bottom of 1747-ASB module. Make sure they are not connected to anything.

- (1) 8 indicates the 1747-ASB module has encountered an unrecoverable fault.
- (2) Slot # is a 2-digit decimal slot number between 1 and 31. 31 indicates the offending slot could not be detected.
- (3) The Status Display alternates between these two codes. Code 1 is the incorrect parameter, Code 2 is the expected (saved) parameter's value.
- (4) The Status Display alternates between these two codes. Code 3 indicates a module configuration mismatch.
- (5) The Status Display alternates between these two codes. Code 4 indicates an I/O Error.

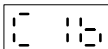
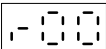
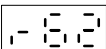
DIP Switch Configuration Mismatch Fault Codes - Codes 1 and 2

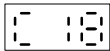
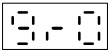
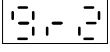
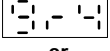
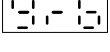
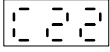
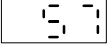
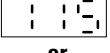
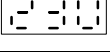
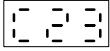
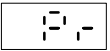
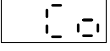
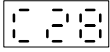
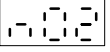
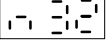
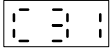
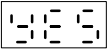
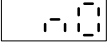
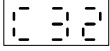
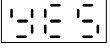
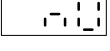
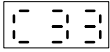
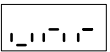
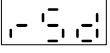
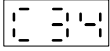
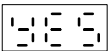
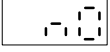
Code 1 ⁽¹⁾	Code 2 ⁽²⁾	Meaning
	 to 	Starting Logical Rack mismatch. 2-digit decimal value previously saved is displayed (rack 00 to rack 62).

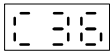
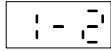
	 or  or  or 	Starting Logical Group mismatch. 1-digit decimal value previously saved is displayed (group 0, group 2, etc.).
	 or  or 	Baud Rate mismatch. Baud rate previously saved is displayed. Abbreviated values are used.
	 or 	Primary/Complementary Selection mismatch. The mode previously saved is displayed.
	 to 	Image Size mismatch. Number of groups from 02 to 32 decimal indicates previously saved selection.
	 or 	Hold Last State (HLS) Selection mismatch. Yes or no indicates if the HLS was (yes) or was not (no) the previously saved selection.
	 or 	Processor Restart Lockout (PRL) Selection mismatch. Yes or no indicates if the PRL was (yes) or was not (no) the previously saved selection.
	 or 	Link Response Selection mismatch. Unrestricted (unr) or Restricted (rSd) indicates previously saved selection.
	 or 	Last Chassis/PLC-3 Backup mismatch.

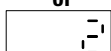
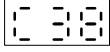
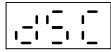
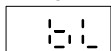
	 <p style="text-align: center;">or</p>  <p style="text-align: center;">or</p> 	<p>Addressing Mode mismatch. 1/2-slot, 1-slot, and 2-slot indicates previously saved selection.</p>
	 <p style="text-align: center;">or</p> 	<p>Specialty I/O Mode mismatch. Discrete (dSc) or Block Transfer (bL) indicates previously saved selection.</p>

- (1) C stands for configuration, the first number from the left is the DIP switch number (SW1, SW2, or SW3). The second number stands for the highest individual switch number (1 - 8). C38 is switch SW3, switch 8.
- (2) This is the saved parameter setting.

I/O Module Configuration Mismatch Fault Codes - Code 3

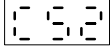
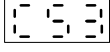
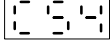
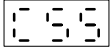
Code 3 ⁽¹⁾	Meaning
	<p>I/O module missing from the previously saved configuration.</p>
	<p>I/O module detected in an unused slot of the previously saved configuration.</p>
	<p>I/O Module Electrical Interface Type. Not the same as the saved configuration such as a DC output module being placed in an AC output slot.</p>
	<p>I/O Module Mix or Class. Not the same as the saved configuration such as a DC 16-point input module placed in an 8 point DC input slot.</p>

(1) The fault code is alternated with the corresponding slot number (L slot#).

I/O Runtime Fault Codes - Code 4

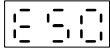
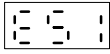
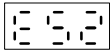
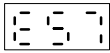
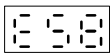
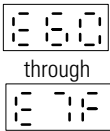
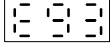
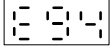
Code 4 ⁽¹⁾	Meaning
	I/O Parity Error
	Hardware Parity Error or module installed or removed under power
	I/O Module Removed Under Power
	File Access Grant Timeout (specialty I/O only)
	I/O Module Fault (generic)
	I/O Module Reported Error Code
	I/O Module Reported Error Code Unknown
	Module Inserted Under Power

(1) The fault code is alternated with the corresponding slot number (L slot#).

Application Examples

This chapter presents two SLC 500 examples and one PLC-5/40 example. The application examples consist of:

- system overview
- device configuration
- processor image
- 1747-ASB module configuration details
- mapping details
- address label explanation
- application program excerpt

The following is a very basic SLC 500 remote I/O application example. This application consists of an SLC 5/02 processor controlling one local and one remote chassis of I/O.⁽¹⁾ The local I/O resides in a 4-slot chassis, consisting of:

Basic SLC 500 Example Using and RIO Scanner

- 1746-OW8, 8-point AC/DC relay output module
- 1746-NIO4I, analog I/O combination module (2 current/voltage inputs and 2 current outputs)

A RIO scanner, Catalog Number 1747-SN, resides in slot 3 of the local chassis. The scanner controls one remote 7-slot chassis using one 1747-ASB module.

The 1747-ASB module controls the following I/O modules:

- 1746-IA16, 16-point 100/120 VAC input module in slots one, two, and three
- 1746-OA16, 16-point AC output module in slots four, five, and six

(1) An SLC 5/02 or greater processor is needed for the RIO scanner.

The application is illustrated below. When the switch is closed, bulbs 1 and 2 turn on and an analog signal is moved to analog module output 1, which leads to the meter.

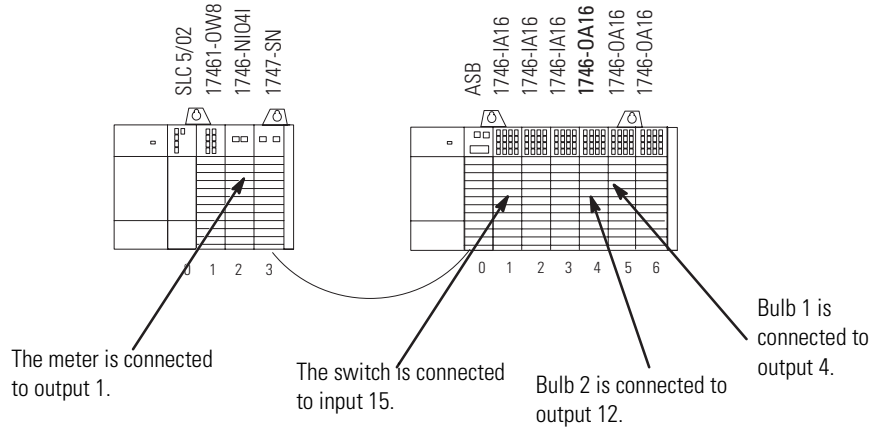

RIO Device Configuration

The 1747-ASB module is configured in the following manner.

Function	1747-ASB Module 1
Starting logical rack number	0
Starting logical group number	0
Image size (number of logical groups)	6
Addressing mode	1-slot
Specialty I/O mode ⁽¹⁾	Discrete
Baud rate	230.4K
Last chassis	Yes
Hold last state	Yes
Processor restart lockout	Yes
Link response ⁽²⁾	Switch position does not matter
Primary/complementary chassis	Complementary

(1) The 1747-SN Series A scanner cannot perform block transfers. Any specialty I/O modules controlled by this scanner must be discretely mapped.

(2) Link response does not matter at 230.4K baud.

For more details on the 1747-SN RIO scanner, refer to the user manual, publication 1747-6.6.

The RIO scanner is configured for 230.4K baud. The SLC 5/02 G-file is configured as shown below:

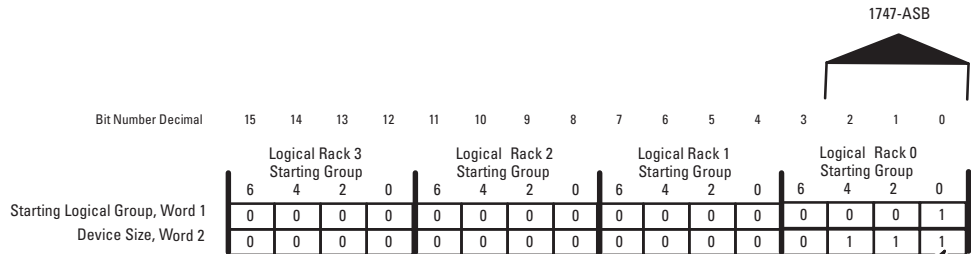

Logical Rack 0 consists of one logical device, beginning at Group 0. The device size is six logical groups.

SLC Processor Image

Shown below are the SLC processor's input and output image. The SLC processor image is comprised of the local I/O module images and the RIO scanner images. The RIO scanner image size is four logical racks. The 1747-ASB module is in the RIO scanner image.

SLC Processor Input Image

Bit Number (Decimal)	15	8	7	0
	NIO4I		NIO4I	
Group 0	IA16	IA16	IA16	IA16
Group 1	IA16	IA16	IA16	IA16
Group 2	IA16	IA16	IA16	IA16
Group 3	Not Used	Not Used	Not Used	Not Used
Group 4	Not Used	Not Used	Not Used	Not Used
Group 5	Not Used	Not Used	Not Used	Not Used
Group 6	Not Used	Not Used	Not Used	Not Used
Group 7	Not Used	Not Used	Not Used	Not Used
Group 0	Not Used	Not Used	Not Used	Not Used
Group 1	Not Used	Not Used	Not Used	Not Used
Group 2	Not Used	Not Used	Not Used	Not Used
Group 3	Not Used	Not Used	Not Used	Not Used
Group 4	Not Used	Not Used	Not Used	Not Used
Group 5	Not Used	Not Used	Not Used	Not Used
Group 6	Not Used	Not Used	Not Used	Not Used
Group 7	Not Used	Not Used	Not Used	Not Used
Group 0	Not Used	Not Used	Not Used	Not Used
Group 1	Not Used	Not Used	Not Used	Not Used
Group 2	Not Used	Not Used	Not Used	Not Used
Group 3	Not Used	Not Used	Not Used	Not Used
Group 4	Not Used	Not Used	Not Used	Not Used
Group 5	Not Used	Not Used	Not Used	Not Used
Group 6	Not Used	Not Used	Not Used	Not Used
Group 7	Not Used	Not Used	Not Used	Not Used

SLC Processor Output Image

Bit Number (Decimal)	15	8	7	0
	NIO4I		OW8 NIO4I	
Group 0	Not Used	Not Used	Not Used	Not Used
Group 1	Not Used	Not Used	Not Used	Not Used
Group 2	Not Used	Not Used	Not Used	Not Used
Group 3	OA16	OA16	OA16	OA16
Group 4	OA16	OA16	OA16	OA16
Group 5	OA16	OA16	OA16	OA16
Group 6	Not Used	Not Used	Not Used	Not Used
Group 7	Not Used	Not Used	Not Used	Not Used
Group 0	Not Used	Not Used	Not Used	Not Used
Group 1	Not Used	Not Used	Not Used	Not Used
Group 2	Not Used	Not Used	Not Used	Not Used
Group 3	Not Used	Not Used	Not Used	Not Used
Group 4	Not Used	Not Used	Not Used	Not Used
Group 5	Not Used	Not Used	Not Used	Not Used
Group 6	Not Used	Not Used	Not Used	Not Used
Group 7	Not Used	Not Used	Not Used	Not Used
Group 0	Not Used	Not Used	Not Used	Not Used
Group 1	Not Used	Not Used	Not Used	Not Used
Group 2	Not Used	Not Used	Not Used	Not Used
Group 3	Not Used	Not Used	Not Used	Not Used
Group 4	Not Used	Not Used	Not Used	Not Used
Group 5	Not Used	Not Used	Not Used	Not Used
Group 6	Not Used	Not Used	Not Used	Not Used
Group 7	Not Used	Not Used	Not Used	Not Used

I = input image
 O = output image
 .3 = slot # RIO scanner uses in local SLC chassis
 .x = scanner word

The default configuration size of the scanner image is 32 words. You can specify that the SLC 5/02 processor scan is less than 32 words with your programming device.

1747-ASB Module Configuration Details

The entire image of the 1747-ASB module is contained in logical rack 0. It does not cross a logical rack boundary. Therefore, it appears as one logical device to the scanner.

SLC Processor Input Image

Bit Number (Decimal)	15	8	7	0	
					I:2.0 & .1 Local SLC Chassis
Group 0	NIO4I			NIO4I	I:3.0 remote slot 1
Group 1	IA16			IA16	I:3.1 remote slot 2
Group 2	IA16			IA16	I:3.2 remote slot 3
Group 3	IA16			IA16	I:3.3 remote slot 4
Group 4	Not Used				I:3.4 remote slot 5
Group 5	Not Used				I:3.5 remote slot 6
Group 6	Not Used				I:3.6 Scanner Image
Group 7	Not Used				I:3.7

SLC Processor Output Image

Bit Number (Decimal)	15	8	7	0	
					O:1.0 Local SLC Chassis
Group 0	NIO4I			OW8 NIO4I	O:2.0 & .1
Group 1	Not Used				O:3.0 remote slot 1
Group 2	Not Used				O:3.1 remote slot 2
Group 3	Not Used				O:3.2 remote slot 3
Group 4	OA16			OA16	O:3.3 remote slot 4
Group 5	OA16			OA16	O:3.4 remote slot 5
Group 6	OA16			OA16	O:3.5 remote slot 6
Group 7	Not Used				O:3.6 Scanner Image
					O:3.7

The 1747-ASB module is configured as the last chassis because it uses the highest numbered logical group in the highest logical rack it resides in.

The 1747-ASB module is configured for hold last state and processor restart lockout. If the RIO communications cable is removed and reconnected during normal RIO communications, the discrete outputs remain in their last state and the 1747-ASB module does not resume communicating with the scanner, until the processor restart lockout terminals are momentarily shorted together. For more information regarding processor restart lockout, refer to chapter 4.

The 1747-ASB module is configured as a complementary chassis. Because complementary I/O is *not* being used, there is no need for a primary chassis.

1747-ASB Module I/O Mapping Details

The 1747-ASB module is configured for 1-slot addressing. Its image starts at group 0 of logical rack 0 and is sized for six logical groups. There are six 16-bit words of input and output image for its three 16-point input and output modules.

Three input and output image words are not used. However, when using 16-point I/O, 1-slot addressing provides I/O configuration flexibility. The modules can be inserted into any slot, in any order.

Slots 1, 2, and 3 contain 16-point input modules. The output words assigned to these slots are unused.

Slots 4, 5, and 6 contain 16-point output modules. The input words assigned to these slots are unused.

SLC Processor Input Image

		Bit Number (Decimal)	15	8	7	0	
Logical Rack 0	Group 0		NIO4I		NIO4I		I:2.0 & .1
	Group 1		IA16		IA16		I:3.0
	Group 2		IA16		IA16		I:3.1
	Group 3		IA16		IA16		I:3.2
	Group 4		Not Used				I:3.3
	Group 5		Not Used				I:3.4
	Group 6		Not Used				I:3.5
	Group 7		Not Used				I:3.6
							I:3.7

Local SLC Chassis

- remote slot 1
- remote slot 2
- remote slot 3
- remote slot 4
- remote slot 5
- remote slot 6

Scanner Image

SLC Processor Output Image

		Bit Number (Decimal)	15	8	7	0	
Logical Rack 0	Group 0		NIO4I		OW8		O:1.0
	Group 1		Not Used		NIO4I		O:2.0
	Group 2		Not Used				O:3.0
	Group 3		Not Used				O:3.1
	Group 4		QA16		QA16		O:3.2
	Group 5		QA16		QA16		O:3.3
	Group 6		QA16		QA16		O:3.4
	Group 7		Not Used				O:3.5
							O:3.6
							O:3.7

RIO Address Label Examples

Due to the 1747-ASB module's addressing modes and RIO link operation, the I/O modules controlled by the 1747-ASB module are addressed by the SLC processor based on the slot location of the SN and the word that the I/O module uses in the SN image. A label kit is included with each 1747-ASB module to assist you in addressing I/O modules.

Shown below are examples of how the labels are filled out.

SLC 5/02
1746-0W8
1746-NIO4I
1747-SN

0 1 2 3

The meter is connected to output 1.

0-7 8-15

SN Slot 3

SN Word(s) 0

BT Discrete

Remote SLC System

The 0-7 and 8-15 boxes are checked because the module requires more than one byte of image.

The SN Slot is 3 because that is the slot the scanner occupies in the local SLC chassis.

The SN Word is 0 because it is the SN image word assigned to the IA16. These values are determined by converting the module's logical rack and logical group numbers (logical rack 0, G0) to the corresponding SN words.

ASB
1746-IA16
1746-IA16
1746-IA16
1746-OA16
1746-OA16
1746-OA16

0 1 2 3 4 5 6

Bulb 2 is connected to output 12.

0-7 8-15

SN Slot 3

SN Word(s) 3

BT Discrete

Remote SLC System

The 0-7 and 8-15 boxes are checked because the module requires more than one byte of image.

The SN Slot is 3 because that is the slot the scanner occupies in the local SLC chassis.

The SN Word is 3 because it is the SN image word assigned to the OA16. The value is determined by converting the module's logical rack and logical group numbers (logical rack 0, G3) to the corresponding SN word.

0 1 2 3 4 5 6

Bulb 1 is connected to output 4.

0-7 8-15

SN Slot 3

SN Word(s) 4

BT Discrete

Remote SLC System

The 0-7 and 8-15 boxes are checked because the module requires more than one byte of image.

The SN Slot is 3 because that is the slot the scanner occupies in the local SLC chassis.

The SN Word is 4 because it is the SN image word assigned to the OA16. These values are determined by converting the module's logical rack and logical group numbers (logical rack 0, G4) to the corresponding SN word.

Application Example Program

Shown below is an excerpt from the user program. When the switch is closed, bulbs 1 and 2 turn on and the decimal value 5555 is moved to analog output 1 and is converted to an analog signal.

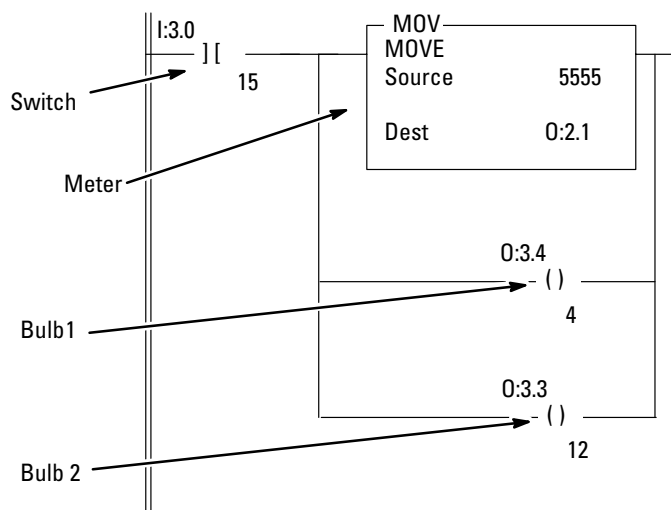

This application consists of an SLC 5/02 processor controlling local and remote I/O.⁽¹⁾ The local I/O resides in a 4-slot chassis, consisting of:

- 1746-OW8, 8-point AC/DC relay output module
- 1746-IA8, 8-point AC input module

Basic SLC 500 Example Using and RIO Scanner

An RIO scanner, Catalog Number 1747-SN, resides in slot 3 of the local chassis. The scanner controls two remote expansion chassis (one 7-slot and one 4-slot) and a RediPANEL.

1747-ASB module 1 controls the following I/O modules:

- 1746-NIO4I, analog module (2 current/voltage inputs and 2 current outputs)
- 1746-IV32, 32-point 24VDC sourcing input module
- 1746-OV32, 32-point 24VDC sinking output module
- 1746-OB16, 16-point DC sourcing output module
- 1746-OA16, 16-point AC output module

(1) An SLC 5/02 or greater processor is needed for the RIO scanner.

1747-ASB module 2 controls the following I/O modules:

- 1746-OA8, 8-point AC output module
- 1746-IO12, 6-point input/output module
- 1746-IA16, 16-point AC input module

The application is illustrated below. When the switch is closed, bulbs 1 and 2 turn on and an analog signal is moved to analog module output 1, which leads to the meter.

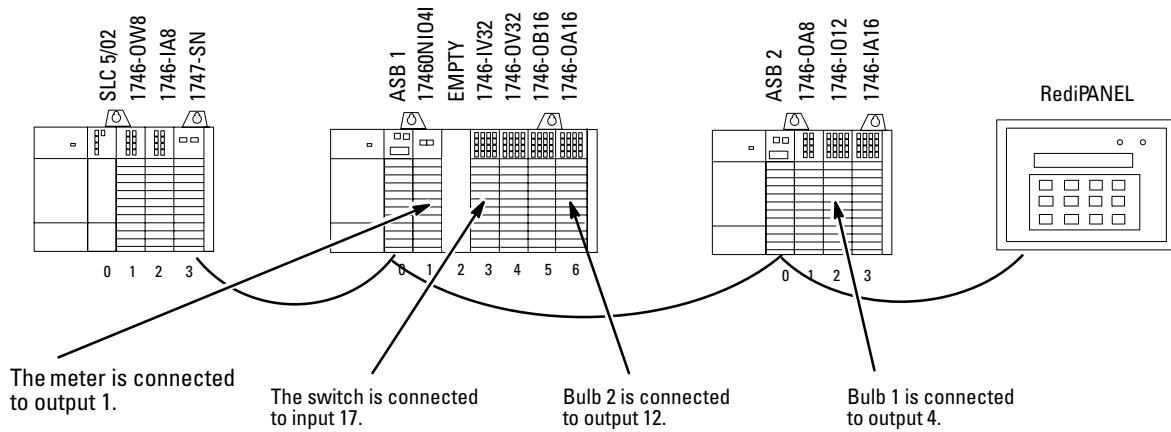

RIO Device Configuration

The 1747-ASB modules and RediPANEL are configured in the following manner.

Function	1747-ASB Module 1	1747-ASB Module 2	RediPANEL ⁽¹⁾
Starting logical rack number	1	0	2
Starting logical group number	6	0	4
Image size (number of logical groups)	6	2	4
Addressing mode	1-slot	2-slot	Not applicable
Specialty I/O mode ⁽²⁾	Discrete	Discrete	Not applicable
Baud rate	230.4K	230.4K	230.4K
Last chassis	No	Yes	Yes
Hold last state	Yes	No	Not applicable
Processor restart lockout	Yes	No	Not applicable
Link response ⁽³⁾	Switch position does not matter	Switch position does not matter	Not applicable
Primary/complementary chassis	Complementary	Complementary	Not applicable

- (1) The only part of the RediPANEL configuration that is important is the RIO address and baud rate.
- (2) The 1747-SN Series A scanner cannot perform block transfers. Any specialty I/O modules controlled by this scanner must be discretely mapped.
- (3) Link response does not matter at 230.4K baud.

For more details on the 1747-SN RIO scanner, refer to the user manual.

The RIO scanner is configured for 230.4K baud. The SLC 5/02 G-file is configured as shown below:

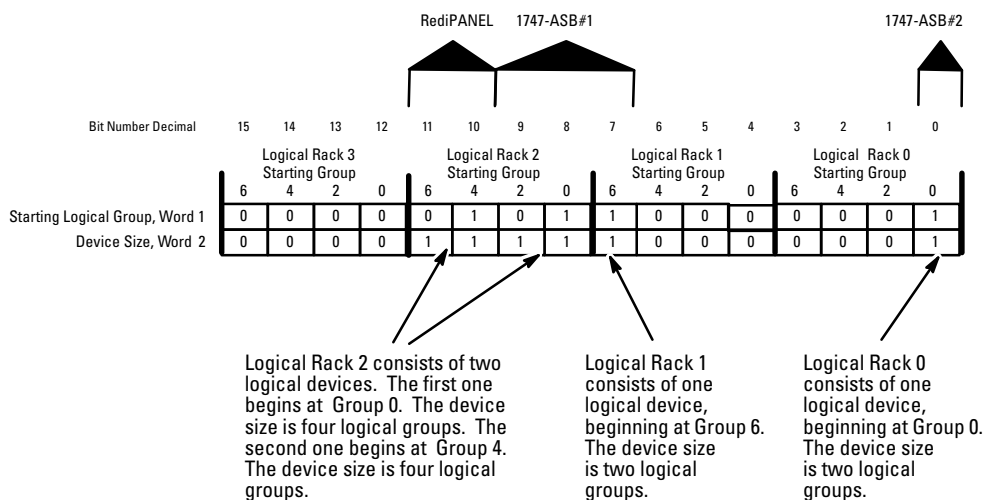

SLC Processor Image

Shown below are the SLC processor's input and output image. The SLC processor image is comprised of the local I/O module images and the RIO scanner images. The RIO scanner image size is four logical racks. 1747-ASB module 1, 1747-ASB module 2, and the RediPANEL are in the RIO scanner image.

SLC Processor Input Image				SLC Processor Output Image			
		Bit Number (Decimal)	15	8	7	0	
		Local SLC Chassis					
Logical Rack 0	Group 0		I012		IA8		I:2.0
	Group 1		IA16		IA16		I:3.0
	Group 2		Not Used				I:3.2
	Group 3		Not Used				I:3.3
	Group 4		Not Used				I:3.4
	Group 5		Not Used				I:3.5
	Group 6		Not Used				I:3.6
	Group 7		Not Used				I:3.7
Logical Rack 1	Group 0		Not Used				I:3.8
	Group 1		Not Used				I:3.9
	Group 2		Not Used				I:3.10
	Group 3		Not Used				I:3.11
	Group 4		Not Used				I:3.12
	Group 5		Not Used				I:3.13
	Group 6		NIO4I		NIO4I		I:3.14
	Group 7		NIO4I		NIO4I		I:3.15
Logical Rack 2	Group 0		IV32		IV32		I:3.16
	Group 1		IV32		IV32		I:3.17
	Group 2						I:3.18
	Group 3						I:3.19
	Group 4						I:3.20
	Group 5						I:3.21
	Group 6						I:3.22
	Group 7						I:3.23
Logical Rack 3	Group 0		Not Used				I:3.24
	Group 1		Not Used				I:3.25
	Group 2		Not Used				I:3.26
	Group 3		Not Used				I:3.27
	Group 4		Not Used				I:3.28
	Group 5		Not Used				I:3.29
	Group 6		Not Used				I:3.30
	Group 7		Not Used				I:3.31
				Scanner Image			
		1747-ASB Module 2					
		1747-ASB Module 1					
		RediPANEL					
Logical Rack 0	Group 0		I012		OW8		O:1.0
	Group 1		QA8		QA8		O:3.0
	Group 2		Not Used				O:3.1
	Group 3		Not Used				O:3.3
	Group 4		Not Used				O:3.4
	Group 5		Not Used				O:3.5
	Group 6		Not Used				O:3.6
	Group 7		Not Used				O:3.7
Logical Rack 1	Group 0		Not Used				O:3.8
	Group 1		Not Used				O:3.9
	Group 2		Not Used				O:3.10
	Group 3		Not Used				O:3.11
	Group 4		Not Used				O:3.12
	Group 5		Not Used				O:3.13
	Group 6		NIO4O		NIO4O		O:3.14
	Group 7		NIO4O		NIO4O		O:3.15
Logical Rack 2	Group 0		OV32		OV32		O:3.16
	Group 1		OV32		OV32		O:3.17
	Group 2		OB16		OB16		O:3.18
	Group 3		OA16		OA16		O:3.19
	Group 4						O:3.20
	Group 5						O:3.21
	Group 6						O:3.22
	Group 7						O:3.23
Logical Rack 3	Group 0		Not Used				O:3.24
	Group 1		Not Used				O:3.25
	Group 2		Not Used				O:3.26
	Group 3		Not Used				O:3.27
	Group 4		Not Used				O:3.28
	Group 5		Not Used				O:3.29
	Group 6		Not Used				O:3.30
	Group 7		Not Used				O:3.31

1747-ASB Module 1 Configuration Details

Because 1747-ASB module 1's image crosses the logical rack boundary of racks 1 and 2, 1747-ASB module 1 appears as two logical devices to the RIO scanner.

SLC Processor Input Image				SLC Processor Output Image			
		Bit Number (Decimal)	15	8	7	0	
Logical Rack 1	Group 6		NIO4I		NIO4I		I:3.14
	Group 7		NIO4I		NIO4I		I:3.15
	Group 0		IV32		IV32		I:3.16
	Group 1		IV32		IV32		I:3.17
Logical Rack 2	Group 2						I:3.18
	Group 3						I:3.19
	Group 4						I:3.20
	Group 5						I:3.21
	Group 6						I:3.22
	Group 7						I:3.23
					1747-ASB Module 1		
				RediPANEL			
Logical Rack 1	Group 6		NIO4O		NIO4O		O:3.14
	Group 7		NIO4O		NIO4O		O:3.15
	Group 0		OV32		OV32		O:3.16
	Group 1		OV32		OV32		O:3.17
	Group 2		OB16		OB16		O:3.18
	Group 3		OA16		OA16		O:3.19
	Group 4						O:3.20
	Group 5						O:3.21
Logical Rack 2	Group 6						O:3.22
	Group 7						O:3.23
					1747-ASB Module 1		
				RediPANEL			

1747-ASB module 1 is not configured as the last chassis because the highest numbered logical group it uses (Group 3) is not the highest numbered logical group in the highest logical rack it resides in. The RediPANEL uses the highest numbered logical group (Group 7) in logical rack 2.

1747-ASB module 1 is configured for hold last state and processor restart lockout. If the RIO communications cable is removed and reconnected during normal RIO communications, the discrete outputs remain in their last state and the 1747-ASB module does not resume communicating with the scanner, until the processor restart lockout terminals are momentarily shorted together. For more information regarding processor restart lockout, refer to chapter 4.

1747-ASB module 1 is configured as a complementary chassis. Because complementary I/O is *not* being used, there is no need for a primary chassis.

1747-ASB Module 2 Configuration Details

Because 1747-ASB module 2's image does not cross the logical rack boundary, 1747-ASB module 2 appears as one logical device to the scanner.

SLC Processor Input Image				SLC Processor Output Image						
Bit Number	(Decimal)	15	8 7	0	Bit Number	(Decimal)	15	8 7	0	
Logical Rack 0	Group 0	I012		I:3.0	Logical Rack 0	Group 0	O012		O:3.0	
	Group 1	IA16	IA16	I:3.1		Group 1				O:3.1
	Group 2	Not Used		I:3.2		Group 2	Not Used			O:3.2
	Group 3	Not Used		I:3.3		Group 3	Not Used			O:3.3
	Group 4	Not Used		I:3.4		Group 4	Not Used			O:3.4
	Group 5	Not Used		I:3.5		Group 5	Not Used			O:3.5
	Group 6	Not Used		I:3.6		Group 6	Not Used			O:3.6
	Group 7	Not Used		I:3.7		Group 7	Not Used			O:3.7

1747-ASB module 2 is configured as last chassis because it has the highest numbered logical group (group 1) in the highest numbered logical rack (rack 0).

1747-ASB module 2 is not configured for hold last state and processor restart lockout. If the RIO communications cable is removed and reconnected during normal RIO communications, the discrete outputs are reset and the 1747-ASB module automatically resumes communicating with the scanner.

1747-ASB module 2 is configured as a complementary chassis. Because complementary I/O is *not* being used, there is no need for a primary chassis.

1747-ASB Module 1 I/O Mapping Details

Because 1747-ASB module 1 is configured for 1-slot addressing, has six logical groups and six slots available for I/O, all of the slots present are mapped into the scanner image. No extra slots in the chassis, or extra words in the image remain.

Because the specialty I/O mode chosen is discrete mode and the 1747-ASB module is configured for 1-slot addressing, all specialty modules that have two words or less of input and output image are discretely mapped.

The 1746-NIO4I module requires two input and two output words. Therefore, it is discretely mapped. When 1-slot addressing is selected, two words of input image and two words of output image are available for each slot pair. Because it requires both words of the input and output image, slot 2 must remain empty. If an I/O module is inserted into slot 2, a 1747-ASB module error occurs.

Due to slot pairing, two 32-point modules that have opposite functions (one input and one output), are allowed in one slot pair using 1-slot addressing. The 32-point input module, Catalog Number 1746-IV32, installed in slot 3 uses the input image words assigned to slots 3 and 4. No input image is available for slot 4. Slot 4 can use the output image that slot 3 is not using. Therefore, a 32-point output module, Catalog Number 1746-OV32 uses the output image assigned to slots 3 and 4.

Slots 5 and 6 contain 16-point output modules. The input words assigned to these slots are not used.

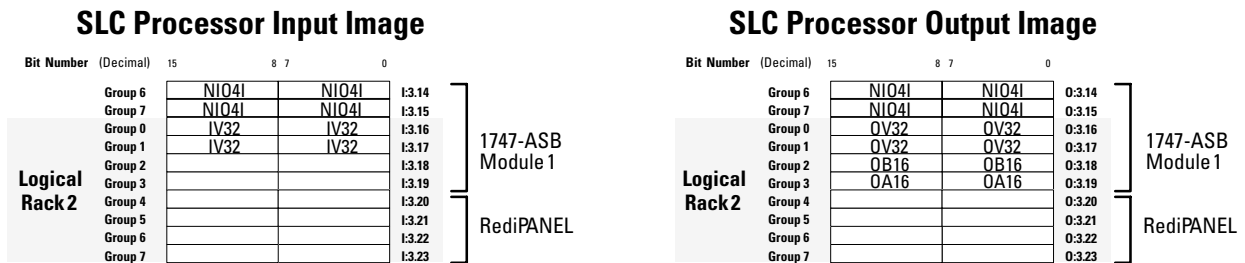

1747-ASB Module 2 I/O Mapping Details

Because 1747-ASB module 2 is configured for 2-slot addressing, has two logical groups and three slots available for I/O, all of the slots present are mapped into the scanner image. One extra byte of input

and output image remain unassigned to any slot because there is no slot 4 in the chassis. Due to slot pairing, slot 3 can use the extra image space.

Because the specialty I/O mode chosen is discrete mode and the 1747-ASB module is configured for 2-slot addressing, all specialty modules having one word or less of input and output image are discretely mapped.

Slot 1 contains an 8-point output module, Catalog Number 1746-OA8, that uses the output image assigned to slot 1. The input image assigned to slot 1 is unused. Slot 2 contains a combination module, Catalog Number 1746-IO12 that uses the input and output byte assigned to slot 2.

Because there is no slot 4, the image assigned to slot 4 can be used by slot 3. A 16-point input module, Catalog Number 1746-IA16 is installed in slot 3, using the input images assigned to slots 3 and 4. The output image for slots 3 and 4 is not used.

SLC Processor Input Image

Group	Bit Number (Decimal)		Address
	15	0	
Group 0	IO12		I:3.0
Group 1	IA16	IA16	I:3.1
Group 2	Not Used		I:3.2
Group 3	Not Used		I:3.3
Group 4	Not Used		I:3.4
Group 5	Not Used		I:3.5
Group 6	Not Used		I:3.6
Group 7	Not Used		I:3.7
Group 0	Not Used		I:3.8

1747-ASB Module 2

SLC Processor Output Image

Group	Bit Number (Decimal)		Address
	15	0	
Group 0	IO12	OA8	O:3.0
Group 1			O:3.1
Group 2	Not Used		O:3.2
Group 3	Not Used		O:3.3
Group 4	Not Used		O:3.4
Group 5	Not Used		O:3.5
Group 6	Not Used		O:3.6
Group 7	Not Used		O:3.7
Group 0	Not Used		O:3.8

1747-ASB Module 2

RIO Address Label Examples

Due to the 1747-ASB module's addressing modes and RIO link operation, the I/O modules controlled by the 1747-ASB module are addressed by the SLC processor based on the slot location of the SN and the word that the I/O module uses in the SN image. A label kit is included with each 1747-ASB module to assist you in addressing I/O modules.

Shown below are examples of how the labels are filled out.

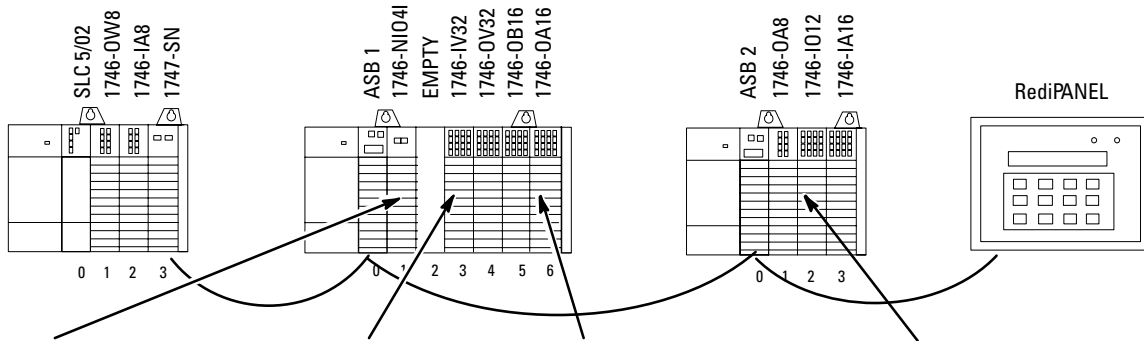

The meter is connected to output 1.

0-7 <input checked="" type="checkbox"/>	8-15 <input checked="" type="checkbox"/>
SN Slot <u>3</u>	
SN Word(s) <u>14, 15</u>	
BT <input type="checkbox"/> Discrete <input checked="" type="checkbox"/>	
Remote SLC™ System	

The 0-7 and 8-15 boxes are checked because the module requires more than one byte of image.
 The SN Slot is 3 because that is the slot the scanner occupies in the local SLC chassis.
 The SN Words are 14, 15 because they are the SN image words assigned to the NIO41. These values are determined by converting the module's logical rack and logical group numbers (logical rack 1, G6, G7) to the corresponding SN words.

The switch is connected to input 17.

0-7 <input checked="" type="checkbox"/>	8-15 <input checked="" type="checkbox"/>
SN Slot <u>3</u>	
SN Word(s) <u>16, 17</u>	
BT <input type="checkbox"/> Discrete <input checked="" type="checkbox"/>	
Remote SLC™ System	

The 0-7 and 8-15 boxes are checked because the module requires more than one byte of image. Bits 16 to 31 must be converted to bits 0 to 15 in the SN image, and the next word (word 17) used for the I/O reference.⁽¹⁾
 The SN Slot is 3 because that is the slot the scanner occupies in the local SLC chassis.
 The SN Words are 16, 17 because they are the SN image words assigned to the IV32. These values are determined by converting the module's logical rack and logical group numbers (logical rack 2, G0, G1) to the corresponding SN words.

Bulb 2 is connected to output 12.

0-7 <input checked="" type="checkbox"/>	8-15 <input checked="" type="checkbox"/>
SN Slot <u>3</u>	
SN Word(s) <u>19</u>	
BT <input type="checkbox"/> Discrete <input checked="" type="checkbox"/>	
Remote SLC™ System	

The 0-7 and 8-15 boxes are checked because the module requires more than one byte of image.
 The SN Slot is 3 because that is the slot the scanner occupies in the local SLC chassis.
 The SN Word is 19 because it is the SN image word assigned to the OA16. The value is determined by converting the module's logical rack and logical group numbers (logical rack 2, G3) to the corresponding SN word.

Bulb 1 is connected to output 4.

0-7 <input type="checkbox"/>	8-15 <input checked="" type="checkbox"/>
SN Slot <u>3</u>	
SN Word(s) <u>0</u>	
BT <input type="checkbox"/> Discrete <input checked="" type="checkbox"/>	
Remote SLC™ System	

The 8-15 box is checked because the module requires the most significant byte of image. Bits 0 to 7 must be converted to bits 8 to 15 in the SN image.⁽²⁾
 The SN Slot is 3 because that is the slot the scanner occupies in the local SLC chassis.
 The SN Word is 0 because it is the SN image word assigned to the IO12. These values are determined by converting the module's logical rack and logical group numbers (logical rack 0, G0) to the corresponding SN word.

(1) Input bits 16 to 31 must be converted to 0 to 15 by subtracting 16. Therefore, Input Bit 17 is converted to 1.

(2) Input and Output bits 0 to 7 must be converted to 8 to 15 by adding 8. Therefore, Input bit 4 is converted to 12.

Application Example Program

Shown below is an excerpt from the user program. When the switch is closed, bulbs 1 and 2 turn on and the decimal value 5555 is moved to analog output 1 and is converted to an analog signal.

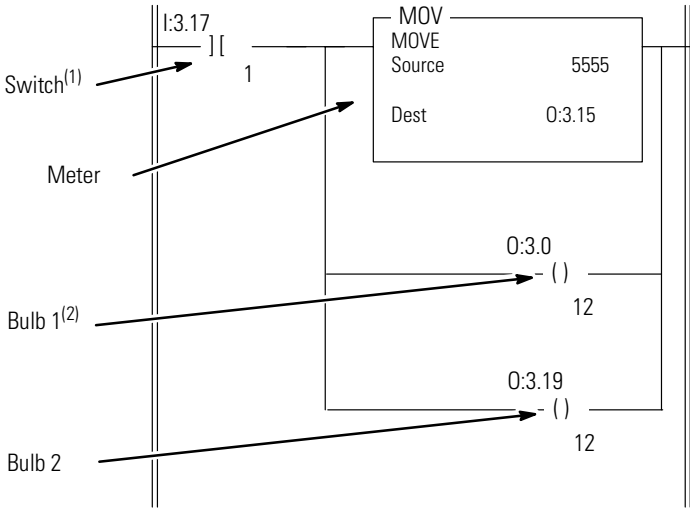

- (1) Input bits 16–31 must be converted to 0–15 by subtracting 16. Therefore, Input bit 17 is converted to 1.
- (2) Input and Output bits 0–7 must be converted to 8–15 by adding 8. Therefore, Input bit 12 is converted to 4.

The following is another representation of what is discussed above.

This application consists of a PLC-5/40 processor controlling local and remote I/O.

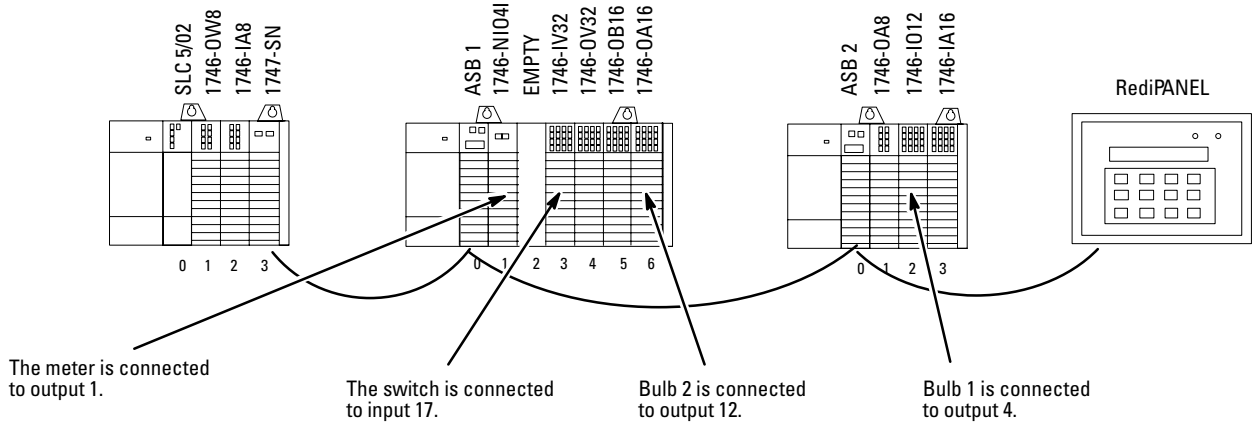

PLC-5 Example

The PLC-5/40 built-in scanner controls two 1747-ASB modules. 1747-ASB module 1 controls a 7-slot and 10-slot chassis. The I/O modules residing in those chassis are:

- 1746-NIO4V, analog module (2 current or voltage inputs and 2 voltage outputs)
- 1746-OW8, 8-point AC/DC Relay output module
- 1746-OW16, 16-point AC/DC Relay output module
- 1746-IA16, 16-point AC input module
- 1746-OG16, 16-point TTL output module
- 1746-IG16, 16-point TTL input module
- 1746-OW8, 8-point AC/DC Relay output module
- 1746-OV8, 8-point DC sinking output module
- 1746-OB16, 16-point DC sourcing output module
- 1746-IB16, 16-point DC sinking input module
- 1746-OA8, 8-point AC output module
- 1746-NO4V, analog module (4 voltage outputs)
- 1746-OW16, 16-point AC/DC Relay output module
- 1746-IA16, 16-point AC input module
- 1746-OV16, 16-point DC sinking output module
- 1746-IV16, 16-point DC sourcing input module

1747-ASB module 2 controls a 4-slot chassis. The I/O modules residing in the SLC chassis are:

- 1746-NI4, analog module (4 current inputs)
- 1746-NO4I, analog module (4 current outputs)
- 1746-NIO4I, analog module (2 current or voltage inputs and 2 current outputs)

The application is illustrated on the following page. When the switch is closed, the bulb turns on. An analog signal is sent from the 1746-NIO4I module to meter 1 and a voltage signal is sent from the 1746-NO4V module to meter 2.

For more information regarding the PLC-5/40 processor, refer to the installation manual.

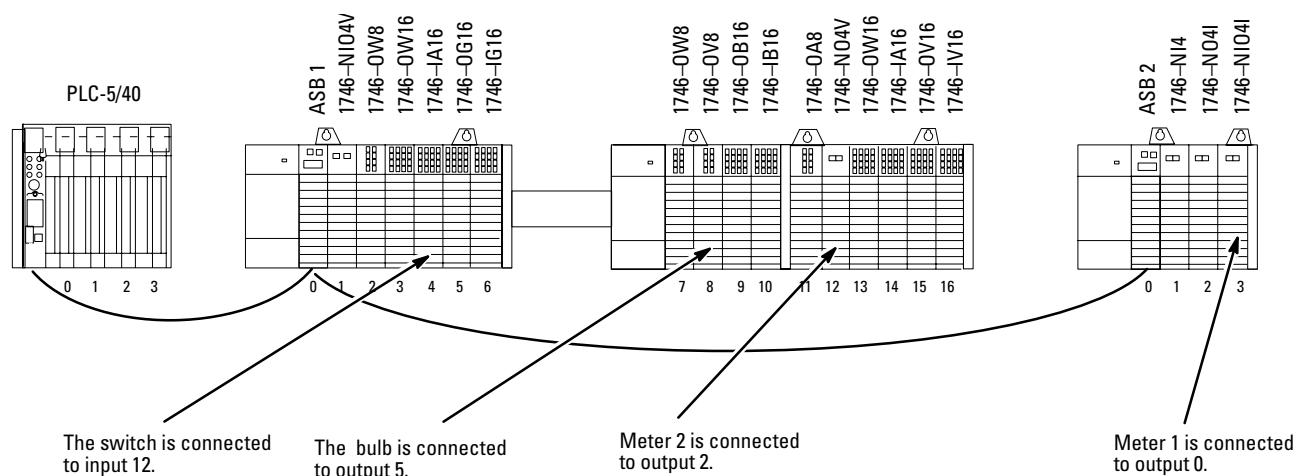

IMPORTANT

All bit numbers in this example are in octal. The 1746 16- and 32-point modules *must* have their LED numbers and wiring terminal numbers labeled in octal. All Series C or later modules include an octal conversion kit which allows you to convert from decimal to octal. This kit is also available as a replacement part through your Rockwell Automation distributor.

RIO Device Configuration

The 1747-ASB modules are configured in the following manner.

Function	1747-ASB Module 1	1747-ASB Module 2
Starting logical rack number	1	3
Starting logical group number	6	0
Image size (number of logical groups)	8	6
Addressing mode	2-slot	1/2-slot
Specialty I/O mode	Block transfer ⁽¹⁾	Discrete
Baud rate	57.6K	57.6K
Last chassis	Yes	Yes
Hold last state	Yes	No
Processor restart lockout	Yes	No
Link response	Unrestricted	Unrestricted
Primary/complementary chassis	Complementary	Complementary

(1) When block transfer mode is selected, all specialty I/O modules are block transfer mapped. Their data is exchanged on the RIO link using RIO block transfers.

The 1771 chassis is configured for 1-slot addressing. The PLC-5/40 is configured for scanner mode operation at 57.6K baud.

PLC Processor Image

Because the 4-slot local chassis is configured for 1-slot addressing, the first four logical groups of logical rack 0 are used for local I/O, the remaining four groups are not used.

Logical racks 1, 2, and 3 are available for remote I/O because they are not used by the local chassis.

PLC Processor Input Image

Bit Number	Octal	17	10 7	0		
Logical Rack 0	Group 0				I:000	
	Group 1				I:001	
	Group 2				I:002	
	Group 3				I:003	
	Group 4				I:004	
	Group 5				I:005	
	Group 6				I:006	
	Group 7				I:007	
Logical Rack 1	Group 0	Not Used			I:010	
	Group 1	Not Used			I:01 1	
	Group 2	Not Used			I:012	
	Group 3	Not Used			I:013	
	Group 4	Not Used			I:014	
	Group 5	Not Used			I:015	
	Group 6		NI04V			I:016
	Group 7	IA16		IA16		I:017
Logical Rack 2	Group 0	IG16		IG16	I:020	
	Group 1				I:021	
	Group 2	IB16		IB16	I:022	
	Group 3	NO4V			I:023	
	Group 4	IA16		IA16	I:024	
	Group 5	IV16		IV16	I:025	
	Group 6	Not Used			I:026	
	Group 7	Not Used			I:027	
Logical Rack 3	Group 0	NI4		NI4	I:030	
	Group 1	NI4		NI4	I:031	
	Group 2	NI4		NI4	I:032	
	Group 3	NI4		NI4	I:033	
	Group 4	NI04I		NI04I	I:034	
	Group 5	NI04I		NI04I	I:035	
	Group 6	Not Used			I:036	
	Group 7	Not Used			I:037	

PLC Processor Output Image

Bit Number	Octal	17	10 7	0		
Logical Rack 0	Group 0				Q:000	
	Group 1				Q:001	
	Group 2				Q:002	
	Group 3				Q:003	
	Group 4				Q:004	
	Group 5				Q:005	
	Group 6				Q:006	
	Group 7				Q:007	
Logical Rack 1	Group 0	Not Used			Q:010	
	Group 1	Not Used			Q:01 1	
	Group 2	Not Used			Q:012	
	Group 3	Not Used			Q:013	
	Group 4	Not Used			Q:014	
	Group 5	Not Used			Q:015	
	Group 6		OW8		NI04V	Q:016
	Group 7	OW16		OW16		Q:017
Logical Rack 2	Group 0	OG16		OG16	Q:020	
	Group 1	OV8		OV8	Q:021	
	Group 2	OB16		OB16	Q:022	
	Group 3	NO4V		OA8	Q:023	
	Group 4	OW16		OW16	Q:024	
	Group 5	OV16		OV16	Q:025	
	Group 6	Not Used			Q:026	
	Group 7	Not Used			Q:027	
Logical Rack 3	Group 0	NO4I		NO4I	Q:030	
	Group 1	NO4I		NO4I	Q:031	
	Group 2	NO4I		NO4I	Q:032	
	Group 3	NO4I		NO4I	Q:033	
	Group 4	NI04I		NI04I	Q:034	
	Group 5	NI04I		NI04I	Q:035	
	Group 6	Not Used			Q:036	
	Group 7	Not Used			Q:037	

1747-ASB Module 1 Configuration Details

Because the image of the 1747-ASB module 1 crosses logical rack boundary 1 and 2, 1747-ASB module 1 appears as two logical devices to the RIO scanner.

PLC Processor Input Image				PLC Processor Output Image								
Bit Number	Octal	17	10	7	0	Bit Number	Octal	17	10	7	0	
Logical Rack 1	Group 0	Not Used		I:010		Logical Rack 1	Group 0	Not Used		O:010		
	Group 1	Not Used		I:011			Group 1	Not Used		O:011		
	Group 2	Not Used		I:012			Group 2	Not Used		O:012		
	Group 3	Not Used		I:013			Group 3	Not Used		O:013		
	Group 4	Not Used		I:014			Group 4	Not Used		O:014		
	Group 5	Not Used		I:015			Group 5	Not Used		O:015		
	Group 6		NI04V		I:016		Group 6	QW8	NI04V		O:016	
	Group 7	IA16	IA16		I:017		Group 7	QW16	QW16		O:017	
Logical Rack 2	Group 0	IG16	IG16		I:020		Group 0	QG16	QG16		O:020	
	Group 1				I:021		Group 1	QV8	QV8		O:021	
	Group 2	IB16	IB16		I:022		Group 2	QB16	QB16		O:022	
	Group 3	NO4V			I:023		Group 3	NO4V	QA8		O:023	
	Group 4	IA16	IA16		I:024		Group 4	QW16	QV16		O:024	
	Group 5	IV16	IV16		I:025		Group 5	QV16	QV16		O:025	
	Group 6	Not Used		I:026		Group 6	Not Used		O:026			
	Group 7	Not Used		I:027		Group 7	Not Used		O:027			

1747-ASB module 1 is configured for last chassis because it has the highest numbered logical group (group 5) in its highest numbered logical rack (logical rack 2).

1747-ASB module 1 is configured for hold last state and processor restart lockout. If the RIO communications cable is removed and reconnected during normal RIO communications, the discrete outputs remain in their last state and the 1747-ASB module does not resume communicating with the scanner until the processor restart lockout terminals are momentarily shorted together. For more information regarding processor restart lockout, refer to chapter 4.

1747-ASB module 1 is configured as a complementary chassis. Because complementary I/O is not being used, there is no need for a primary chassis.

The 1747-ASB module 1 response time is unrestricted because the PLC-5/40 does not require a restricted response time.

IMPORTANT

Selecting processor restart lockout disables PLC auto configurations on the 1747-ASB module except for initial powerup. If processor restart lockout is not selected, you are able to perform PLC auto configurations on the 1747-ASB module.

1747-ASB Module 2 Configuration Details

Because the image of 1747-ASB module 2 does not cross a logical rack boundary, 1747-ASB module 2 appears as one logical device to the scanner.

PLC Processor Input Image					PLC Processor Output Image							
Bit Number	Octal	17	10	7	0	Bit Number	Octal	17	10	7	0	
Logical Rack 3	Group 0		NI4		NI4	I:030	Group 0		NO4I		NO4I	O:030
	Group 1		NI4		NI4	I:031	Group 1		NO4I		NO4I	O:031
	Group 2		NI4		NI4	I:032	Group 2		NO4I		NO4I	O:032
	Group 3		NI4		NI4	I:033	Group 3		NO4I		NO4I	O:033
	Group 4		NI04I		NI04I	I:034	Group 4		NI04I		NI04I	O:034
	Group 5		NI04I		NI04I	I:035	Group 5		NI04I		NI04I	O:035
	Group 6		Not Used			I:036	Group 6		Not Used			O:036
Group 7		Not Used			I:037	Group 7		Not Used			O:037	

1747-ASB module 2 is configured for last chassis because it has the highest logical group (group 5) in its highest numbered logical rack (logical rack 3).

1747-ASB module 2 is not configured for hold last state and processor restart lockout. If the RIO communications cable is removed and reconnected during normal RIO communications, the discrete outputs are reset and the 1747-ASB module automatically resumes communicating with the PLC-5/40.

1747-ASB module 2 is configured as a complementary chassis. Because complementary I/O is not being used, there is no need for a primary chassis.

The 1747-ASB module 2 response time is unrestricted because the PLC-5/40 does not require a restricted response time.

1747-ASB Module 1 I/O Mapping Details

Because 1747-ASB module 1 is configured for 2-slot addressing, has eight logical groups and 16 I/O slots available, all of the slots present are mapped into the PLC-5/40 image. No extra slots in the chassis or extra words in the image remain. Each slot is assigned one byte in the PLC-5/40 input and output images.

1747-ASB module 1 is configured for block transfer specialty I/O mode. Therefore, all specialty I/O modules are block transfer mapped. If specialty I/O modules are used, their paired slots can only use 8-point (or smaller) discrete input, discrete output, or block transfer mapped specialty modules, as shown below. 16-point discrete output modules can be used if their paired slots have discrete (16-point or less) input modules in them, as shown below. 32-point modules cannot be used with 2-slot addressing.

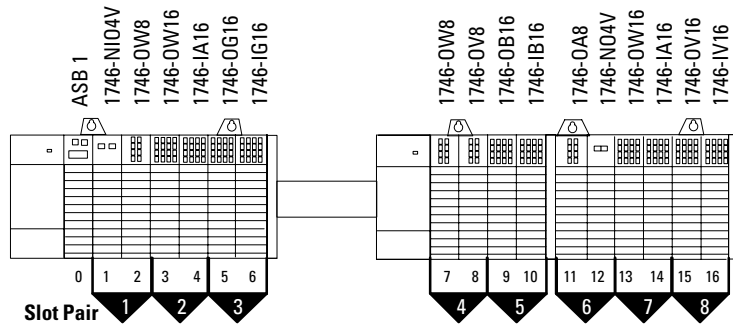

PLC Processor Input Image

Bit Number	Octal	17	10	7	0
Group 0		Not Used			I:010
Group 1		Not Used			I:011
Group 2		Not Used			I:012
Group 3		Not Used			I:013
Group 4		Not Used			I:014
Group 5		Not Used			I:015
Group 6				NI04V	I:016
Group 7		IA16		IA16	I:017
Group 0		IG16		IG16	I:020
Group 1					I:021
Group 2		IB16		IB16	I:022
Group 3		NO4V			I:023
Group 4		IA16		IA16	I:024
Group 5		IV16		IV16	I:025
Group 6		Not Used			I:026
Group 7		Not Used			I:027

Logical Rack 1 (Groups 0-5)
 Logical Rack 2 (Groups 6-7)

1747-ASB Module 1

PLC Processor Output Image

Bit Number	Octal	17	10	7	0
Group 0		Not Used			O:010
Group 1		Not Used			O:011
Group 2		Not Used			O:012
Group 3		Not Used			O:013
Group 4		Not Used			O:014
Group 5		Not Used			O:015
Group 6		OW8		NI04V	O:016
Group 7		OW16		OW16	O:017
Group 0		OG16		OG16	O:020
Group 1		OV8		OV8	O:021
Group 2		OB16		OB16	O:022
Group 3		NO4V		OA8	O:023
Group 4		OW16		OW16	O:024
Group 5		OV16		OV16	O:025
Group 6		Not Used			O:026
Group 7		Not Used			O:027

Logical Rack 1 (Groups 0-5)
 Logical Rack 2 (Groups 6-7)

1747-ASB Module 1

1747-ASB Module 2 I/O Mapping Details

Because 1747-ASB module 2 is configured for 1/2-slot addressing, has six logical groups and three slots available for I/O, all of the slots present are mapped into the PLC-5/40 image. Since slot three cannot be paired with slot four and only two words of image are available, slot three has the two words assigned to it.

1747-ASB module 2 is configured for discrete mode operation. Therefore, all speciality modules that have four or less words of input and output image are discretely mapped, while all specialty modules that have more than four words of input image or output image are block transfer mapped.

Due to slot pairing, a discretely mapped four word analog input and output module are allowed in one slot pair. The 1746-NI4 module in slot one uses the four input words assigned to slots one and two. As a result, slot two cannot use any input image. Conversely, it can use the four output image words assigned to slots one and two which then allows the 1746-NO4I output module to be installed in slot two.

Because slot three has two input and output words assigned to it and the 1746-NIO4I module in slot three requires two input and output words, the 1746-NIO4I module can be installed in slot three. If a four word input or output module is installed in slot three, a 1747-ASB module error occurs because only half of the module's image can be mapped.

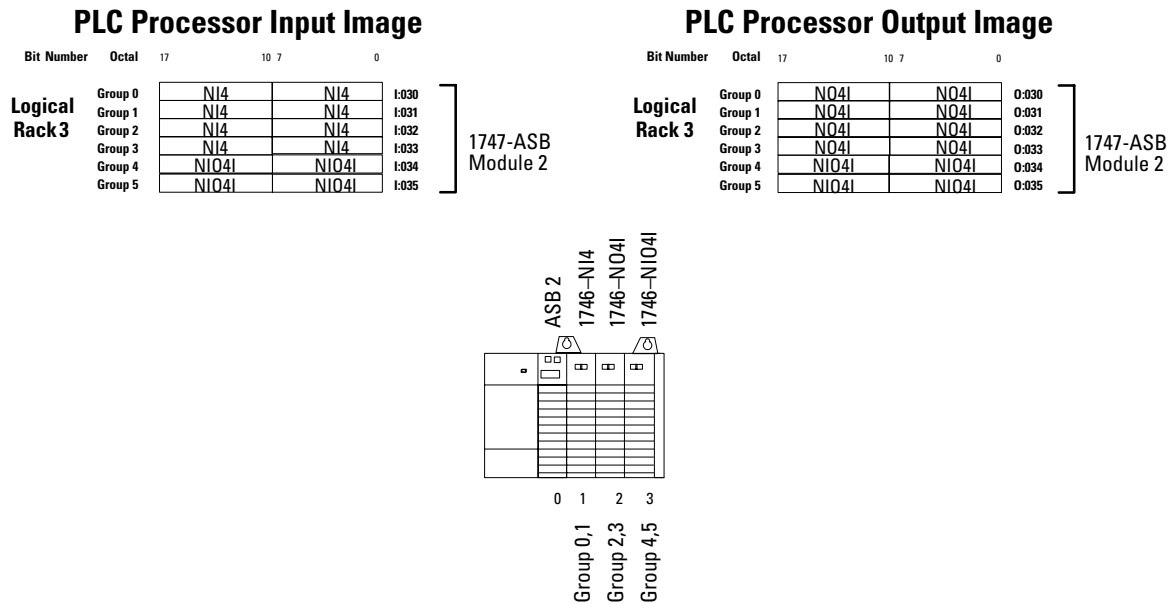

RIO Address Label Examples

Due to the 1747-ASB module's addressing modes and RIO link operation, the I/O modules controlled by the 1747-ASB module are addressed by the PLC processor on a logical rack, logical group basis. A label kit is included with each 1747-ASB module to assist you in assigning the logical rack and logical group designation for each I/O module. Refer to chapter 6 for more information regarding these labels.

Shown below are examples of how the labels are filled out.

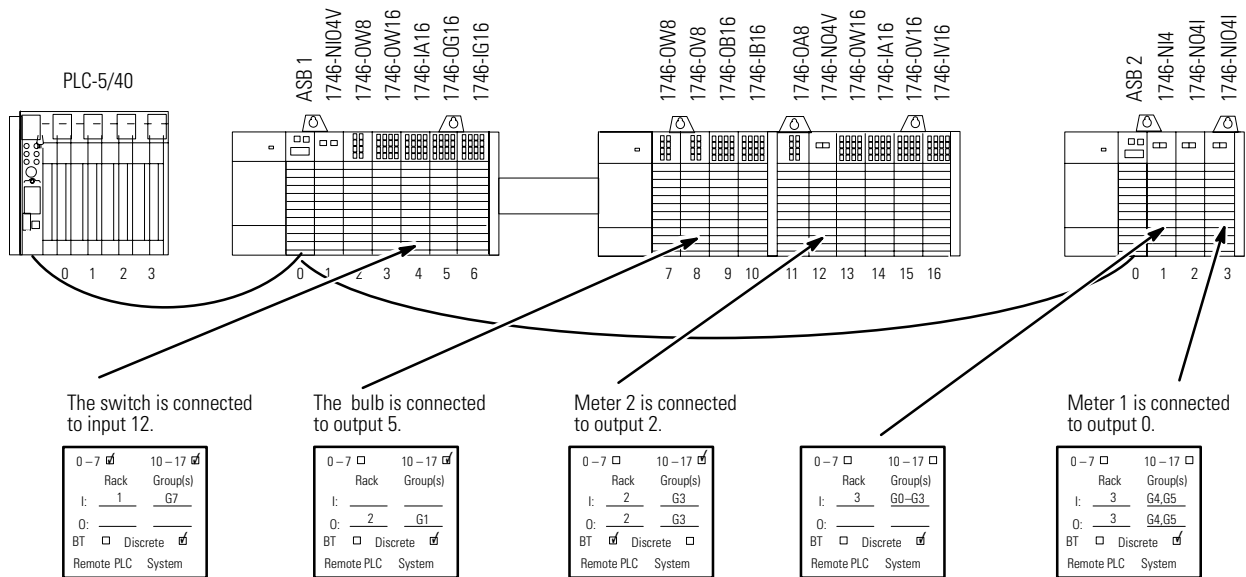

The 0-7 and 10-17 boxes are checked because the module requires more than one byte of image.

The module resides in the PLC-5/40, Input image (I:), logical rack 1, logical group 7.

The discrete box is checked because the module's image is discretely mapped in the PLC-5/40 image.

The 10-17 box is checked because this module requires the high byte of the PLC-5/40 image. 0 to 7 must be converted to 10 to 17 to correspond with the PLC-5/40 image.

The module resides in the PLC, Output image (O:), logical rack 2, logical group 1.

The discrete box is checked because the module's image is discretely mapped in the PLC-5/40 image.

The 10-17 box is checked because this module requires the high byte of the PLC-5/40 image.

The module resides in the PLC, output image (O:), input image (I:), logical rack 2, logical group 3.

The block transfer box is checked because the module's image is block transfer mapped into the PLC-5/40 image.

The 0-7 and 10-17 boxes are not checked because only words are considered when this module is mapped discretely. The NI4 has four words that are discretely mapped into PLC-5/40 image.

The module resides in the PLC-5/40, Input image (I:), logical rack 3, logical groups 0, 1, 2, and 3.

The discrete box is checked because the module's image is discretely mapped in the PLC-5/40 image.

The 0-7 and 10-17 boxes are not checked because only words are considered when this module is mapped discretely. The NI04I has two input and two output words that are discretely mapped into PLC-5/40 image.

The module resides in the PLC-5/40, Input (I:) and Output image (O:), logical rack 3, logical groups 4 and 5.

The discrete box is checked because the module's image is discretely mapped in the PLC-5/40 image.

Application Example Program

Shown below is an excerpt from the user program. When the switch is closed, the bulb illuminates, decimal value 5555 is moved to the 1746-NO4V output 2 (connected to meter 2) and to the 1746-NIO4I output 0 (connected to meter 1).

The inputs to the 1746-IA16 module are in octal. The switch is wired to input 12 (octal) and its value is represented by bit 12 (octal) in the process image. Make sure that the octal label kit 15 and 32-point modules are used to convert their LED filters and wiring labels to octal, for use with the PLC5.

The 1746-NO4V module is block transfer mapped. To write a value to the module, the data must first be written to the appropriate word in N10:0 to N10:3. This integer file was chosen as the block transfer data file for the NO4V. N10:2 corresponds to output 2. The user program must enable the block transfer to the NO4V using a block transfer instruction. The data is not transferred until the next RIO block transfer for this module occurs.

The 1746-NIO4O module is discretely mapped. To write a value to the NIO4I outputs, the value is written to the processor output image (word 0:34 corresponds to output 0 and word 0:35 corresponds to output 1). The data is automatically sent to the processor on the next RIO discrete transfer.

The 1746-OV8 module output is in octal. It has been adjusted because it resides in the high byte of the processor image. The bulb is wired to output 5 that corresponds to bit 40 (octal) of the processor image.

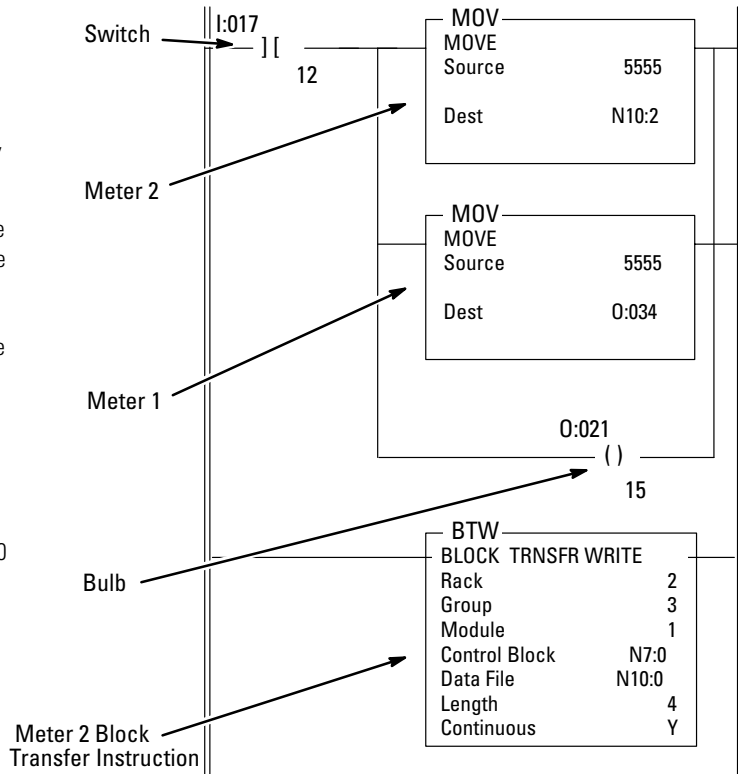

The following is another representation of what is discussed above.

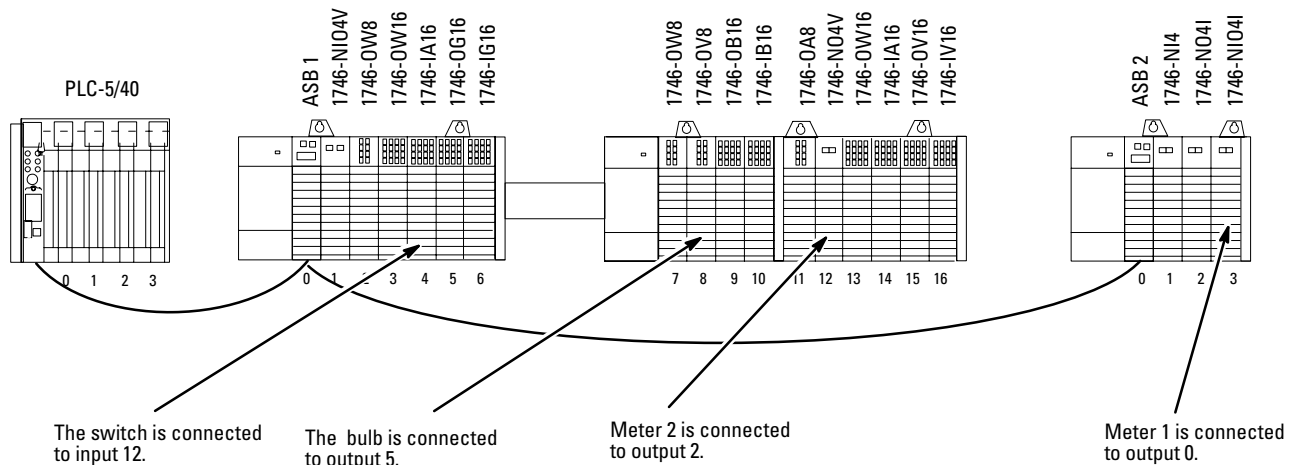

Specifications

This appendix provides adapter and system specifications, as well as throughput information. Topics include:

- adapter operating specifications
- network specifications
- throughput introduction
- calculating throughput

Adapter Operating Specifications

Backplane Current Consumption	375mA at 5V
Operating Temperature	32° F to 140° F (0° C to 60° C)
Storage Temperature	-40° F to +185° F (-40° C to +85° C)
Humidity	5% to 95% noncondensing
Noise Immunity	NEMA standard ICS 2-230
Agency Certification (when product or packaging is marked)	<ul style="list-style-type: none"> • CSA certified • CSA Class I, Division 2 Groups A, B, C, D certified • UL listed • CE marked for all applicable directives • C-Tick marked for all applicable acts

Network Specifications

Baud Rate Determination of Maximum Cable Length and Terminating Resistor.

Table 8.1 Baud Rate Determination of Maximum Cable Length and Terminating Resistor Size

Baud Rate		Maximum Cable Distance (Belden 9463)	Resistor Size
Using Extended Node Capability	57.6K baud	3048 meters (10,000 feet)	82Ω 1/2 Watt
	115.2K baud	1524 meters (5,000 feet)	
	230.4K baud	762 meters (2,500 feet)	
Not Using Extended Node Capability	57.6K baud	3048 meters (10,000 feet)	150Ω 1/2 Watt
	115.2K baud	1524 meters (5,000 feet)	
	230.4K baud	762 meters (2,500 feet)	82Ω 1/2 Watt

Throughput is the time between when a control system senses an input event on an I/O module in a 1747-ASB chassis to when an output event occurs on an I/O module within the same 1747-ASB chassis. There are three types of 1747-ASB module throughput:

Throughput Production

- discrete throughput (time from discretely mapped input to discretely mapped output) *without* block transfers present
- discrete throughput (time from discretely mapped input to discretely mapped output) *with* block transfers present
- block transfer throughput (time from block transfer mapped input to block transfer mapped output)

Discrete Throughput Overview

The 1747-ASB module system discrete throughput is comprised of:

- the total PLC or SLC processor scan time
- the total RIO link scan time
- 1747-ASB module backplane scan time
- the scanner module output delay time (only if scanner is a separate module from the processor, otherwise value is 0)
- the scanner module input delay time (only if scanner is a separate module from the processor, otherwise value is 0)
- the input module delay time
- the output module delay time

In the following example, the input event occurs at a discretely mapped I/O module. The input image of I/O module is read by the 1747-ASB module during a 1747-ASB module backplane scan. The input data is placed into a buffer, which is next read by the scanner during a discrete scan of the RIO link. Once the input data is read by the scanner, it is sent to and read by the PLC or SLC processor.

The response or output data travels back across the RIO link to the 1747-ASB module during a discrete scan. The 1747-ASB module writes the output data to a discretely mapped output module during a 1747-ASB module backplane scan. The output data exits the chassis via the I/O module in order to control the field device.

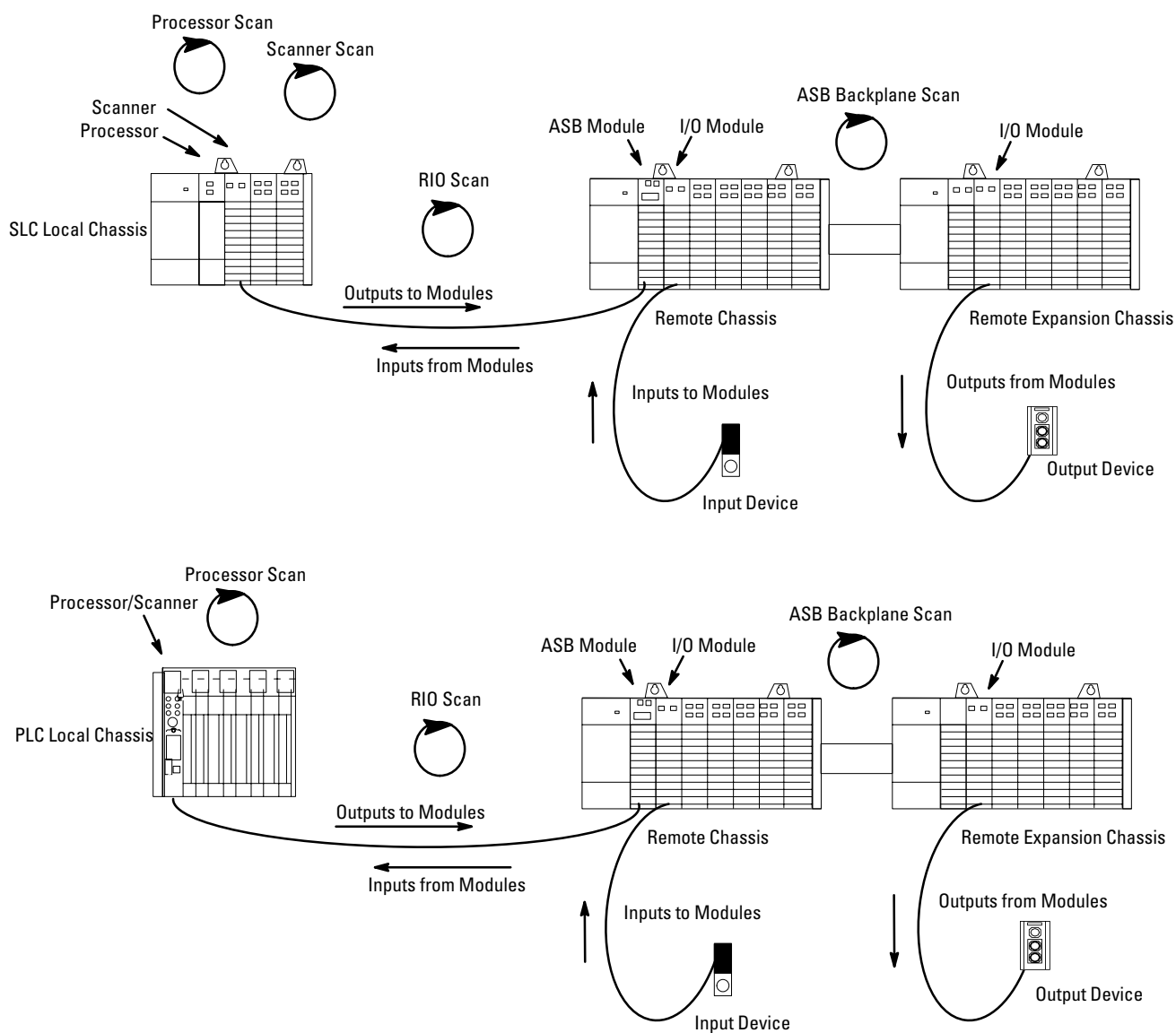

Calculating Throughput

The 1747-ASB module throughput is determined by more than the 1747-ASB module itself. The input and output module delays, scanner scan time, and processor scan time contribute to throughput as well.

Discrete I/O Throughput without Block Transfers Present

The information in this section is used to calculate the discrete throughput of the 1747-ASB module if both conditions are true:

- There are no block transfer mapped I/O modules in the 1747-ASB chassis.
- There are no RIO block transfers occurring on the RIO link to any chassis.

If RIO block transfers are present on the RIO link or if the 1747-ASB chassis has block transfer mapped I/O modules, you *must* use the Discrete I/O Throughput with Block Transfers Present section.

The formula to calculate the maximum 1747-ASB module discrete I/O throughput without block transfers present is:

$$T_{dm-nbt} = 2T_{ps} + 2T_{RIO} + 2T_{bp} + T_{SNo} + T_{SNi} + T_{id} + T_{od} + 10ms^{(1)}$$

T_{dm-nbt} = The maximum 1747-ASB module discrete throughput without block transfers in milliseconds (ms)

To calculate throughput, substitute values for the variables in the formula above. Locate these values in the following documents:

Variable	Variable Description	Location of Variable
T_{ps}	The total processor scan time (ms)	PLC or SLC programming manual
T_{SNi}	The scanner module input delay time (ms) (only if scanner is a separate module, otherwise value is 0)	scanner user manual
T_{SNo}	The scanner module output delay time (ms) (only if scanner is a separate module, otherwise value is 0)	scanner user manual
T_{id}	The input delay time (ms)	SLC I/O technical data and I/O instruction sheets
T_{od}	The output delay time (ms)	SLC I/O technical data and I/O installation instructions
T_{RIO}	The total RIO scan time (ms)	page A-5 of this manual
T_{bp}	1747-ASB module backplane scan time (ms)	page A-6 of this manual

(1) The value of 10ms is for PLC-5/11, -5/20, -5/30, -5/40, and -5/60 processors only. For all other processors the value is not used.

RIO Scan Time Calculation (T_{RIO})

The RIO scan time is calculated by identifying the baud rate and image size of each logical device on the RIO link. Locate the corresponding time value in the following table. If you are using multiple logical devices, add the time values together to determine the total RIO scan time (T_{RIO}).

$$T_{RIO} = T_{\text{adapter 1}} + T_{\text{adapter 2}} + T_{\text{adapter 3}}$$

Table 8.2 RIO Scan Times for Adapters⁽¹⁾

Adapter Size	Baud Rate		
	57.6K	115.2K	230.4K
1/4 logical rack	6.0ms	3.5ms	2.5ms
3/4 logical rack	7.5ms	4.5ms	3.0ms
Full logical rack	9.5ms	5.5ms	3.5ms

(1) The table shown above is based on PLC-5 processors. If another type of processor is used, refer to its user manual for T_{RIO} .

1747-ASB Module Backplane Scan Time (T_{bp})

The 1747-ASB module backplane scan time is determined by the type of I/O modules in the 1747-ASB chassis and the baud rate. To calculate the 1747-ASB module backplane scan time (T_{bp}), first add the I/O module scan times together to determine the base backplane scan time (T_b):

$$T_b(\text{base backplane scan time})^{(1)} = T_{\text{I/O module 1}} + T_{\text{I/O module 2}}$$

Locate the appropriate I/O module scan times in the following table:

Backplane Scan Times (T_b)	
I/O Module	Scan Time (ms)
4-point input	0.210
8-point input	0.210
16-point input	0.325
32 point input	0.560
2 word specialty input	0.625
4 word specialty input	1.100
6 word specialty input	1.575
8 word specialty input	2.048
4-point output	0.170
8-point output	0.170
16-point output	0.273
32-point output	0.470
2-word specialty output	0.620
4-word specialty output	1.028
6-word specialty output	1.440
8-word specialty output	1.745
4-, 6-, and 12-point combination	0.380

Now substitute the base backplane scan time (T_b) into the appropriate equation, based on your baud rate, to solve for the 1747-ASB module backplane scan time (T_{bp}):

Baud Rate	1747-ASB Module Backplane Scan Time (T_{bp})
57.6K baud	$1.15T_b + 1.38$
115.2K baud	$1.32T_b + 1.58$
230.4K baud	$1.67T_b + 2.00$

(1) Only modules mapped to the 1747-ASB image; unmapped modules are not scanned.

Discrete I/O Throughput without Block Transfers Present Example

A PLC 5/40 is controlling an RIO link running at 115.2K baud that has the following adapters:

- One 1747-ASB module configured as 1/2 logical rack with 1-slot addressing and discrete specialty I/O mode
 - slot 1 - 1746-IB16, 16-point input module
 - slot 2 - 1746-OB16, 16-point output module
 - slot 3 - 1746-NIO4I, 2 input/ 2 output analog module
- Two adapters, each configured as a full logical rack
- Three adapters, each configured as a 1/4 logical rack

1. Use the throughput formula to calculate the maximum throughput.

$$T_{dm-nbt} = 2T_{ps} + 2T_{RIO} + 2T_{bp} + T_{SNO} + T_{SNI} + T_{id} + T_{od} + 10ms^{(1)}$$

T_{dm-nbt} = The maximum 1747-ASB module discrete throughput without block transfers in milliseconds (ms)

T_{ps} = 25.0 ms, which is from the PLC 5/40 programming manual

T_{RIO} = The total RIO scan time (ms)

T_{bp} = 1747-ASB module backplane scan time (ms)

T_{SNO} = 0 since you are using a PLC processor with a built in scanner

T_{SNI} = 0 since you are using a PLC processor with a built in scanner

T_{id} = 10.0 ms, which is from I/O module instruction sheets

T_{od} = 1.0 ms, which is from I/O module instruction sheets

$$T_{dm-nbt} = 2(25) + 2T_{RIO} + 2T_{bp} + 0 + 0 + 10.0 + 1.0 + 10ms^{(1)}$$

2. Since there are two unknown values, continue with steps three through seven on the following page.
3. Calculate the 1747-ASB module backplane scan time (T_{bp}).

Determine the backplane scan time for each module in slots one, two, and three.

slot 1 - 1747-IB16, 16-point input module = 0.325ms

slot 2 - 1747-OB16, 16-point output module = 0.273ms

slot 3 - 1746-NIO4I, 2 input/ 2 output analog module = input = 0.625ms output = .620ms⁽²⁾

(1) The value of 10 ms is for PLC-5/11, -5/20, -5/30, -5/40, and -5/60 processors only. For all other PLC-5 processors the value is not required.

(2) Since the 1746-NIO4I has both input and output image, each amount is needed to calculate base backplane scan time (T_b).

These values are listed in the Backplane Scan Time table on page A-6.

4. Add the backplane scan times together for each module in slots one, two, and three.

$$T_{\text{base backplane scan time}} (T_b) = T_{\text{I/O module 1}} + T_{\text{I/O module 2}} + T_{\text{I/O module 3}}$$

$$T_b = 0.325\text{ms} + 0.273\text{ms} + 0.625\text{ms} + 0.620\text{ms}$$

$$T_b = 1.843\text{ms}$$

5. Use the appropriate Total Backplane Scan Time formula found on page A-6 to calculate the total backplane scan time.

$$T_{\text{bp}} = 1.32T_b + 1.58$$

$$T_{\text{bp}} = 1.32(1.843\text{ms}) + 1.58$$

$$T_{\text{bp}} = 4.01\text{ms}$$

6. Calculate the total RIO scan time (T_{RIO}). Locate the baud rate (115.2K) and adapter size which is found in the table on page A-5. Multiply the RIO scan times listed under the 115.2K heading by the number of each different type of rack that you have. Add those numbers together:

$$T_{\text{RIO}} = T_{\text{adapter 1}} + T_{\text{adapter 2}} + T_{\text{adapter 3}}$$

$$T_{\text{RIO}} = 1(4.0\text{ms}) + 2(5.0\text{ms}) + 3(3.5\text{ms})$$

$$T_{\text{RIO}} = 24.5\text{ms}$$

7. Substitute all the values for variables in the throughput formula and solve for throughput:

$$T_{\text{dm-nbt}} = 2T_{\text{ps}} + 2T_{\text{RIO}} + 2T_{\text{bp}} + T_{\text{SNo}} + T_{\text{SNi}} + T_{\text{id}} + T_{\text{od}} + 10\text{ms}^{(1)}$$

$$T_{\text{dm-nbt}} = 2(25) + 2(24.5) + 2(4.01) + 0 + 0 + 10.0 + 1.0 + 10$$

$$T_{\text{dm-nbt}} = 128.02 \text{ ms} = \text{maximum throughput}$$

(1) The value of 10 ms is for PLC-5/11, -5/20, -5/30, -5/40, and -5/60 processors only. For all other PLC-5 processors the value is not required.

Discrete I/O Throughput with Block Transfers Present

The information in this section is used to calculate the discrete throughput of the 1747-ASB module if either of the following conditions are true:

- There are block transfer mapped I/O modules in the 1747-ASB chassis.
- There are RIO block transfers occurring on the RIO link to any chassis.

If RIO block transfers not are present on the RIO link or if the 1747-ASB chassis has no block transfer mapped I/O modules, you *must* use the Discrete I/O Throughput without Block Transfers Present section.

To calculate discrete I/O throughput with block transfers present, use the following formula:

$$T_{dm-bt} = T_{dm-nbt} + 2T_{btX}$$

T_{dm-bt} = The maximum 1747-ASB module discrete throughput with block transfers in milliseconds (ms)

T_{dm-nbt} = The maximum 1747-ASB module discrete throughput without block transfers in milliseconds (ms)

T_{btX} = Additional time due to sending any RIO block transfer data on the RIO link

IMPORTANT

You will need to use the backplane scan times located in the top table on page A-6. You *must* include the time necessary to scan all the words of all the I/O modules in the 1747-ASB chassis, including the block transfer mapped I/O modules. For example, if a 1746-BAS module is used, (T_b) *must* include the time needed to scan 8 input and 8 output words even though the 1746-BAS module consumes only 2 bytes in the 1747-ASB image.

Before determining (T_{btX}), you need to establish the maximum block transfer write or read length that is to be processed by each logical device on the RIO link including the 1747-ASB module.

RIO scan time is increased each time an RIO block transfer is sent to any logical device on the RIO network even if it is not sent to the 1747-ASB module. The scan time increase depends on the number of

words sent in the block transfer and the selected baud rate. RIO link protocol allows for a maximum of one RIO block transfer to be sent to each logical device on the RIO link during any single RIO scan. The RIO scan increase (T_{ri}) for each logical device is:

Baud Rate	RIO Scan Time Increase (T_{ri})
57.6K baud	0.300 x block transfer length + 5.0ms
115.2K baud	0.150 x block transfer length + 3.5ms
230.4K baud	0.075 x block transfer length + 2.0ms

The total increase in the RIO scan time (T_{btX}) is equal to:

$$T_{btX} = \text{sum of } T_{ri} \text{ for all logical devices}$$

Discrete I/O Throughput with Block Transfers Present Example

A PLC 5/40 is controlling a 115.2K baud RIO link that has 3 adapters and 4 logical devices.

1747-ASB module:

- starting logical rack 0, logical group 0
- 12 logical groups (1 1/2 logical racks)
- one 8 word and two 4 word block transfer write/read modules in logical rack 0
- one 2 word block transfer write/read module in logical rack 1

1771-ASB module:

- starting logical rack 2, logical group 0
- 2 logical groups (1/4 logical racks)
- one 64 word block transfer write/read module

1771-ASB module

- starting logical rack 2, logical group 2
- 2 logical groups (1/4 logical racks)
- one 64 word block transfer write/read module

1. T_{dm-nbt} equals $80ms^{(1)}$ for a specific pair of discretely mapped input and output modules. The maximum throughput for these discretely mapped I/O modules when block transfers are present are:

$$T_{dm-bt} = T_{dm-nbt} + 2T_{btx}$$

$$T_{dm-bt} = 80ms + 2T_{btx}$$

2. Determine the maximum length of the block transfer to each logical device. There are two logical devices for the 1747-ASB module. The largest block transfer that is possible with the full logical rack, logical device is 8 words. The largest block transfer that is possible with the 1/2 logical rack, logical device is 2 words.
3. Substitute the maximum length of each logical device into:

$$T_{ri} = 0.150 \times \text{block transfer length} + 3.5ms$$

$$T_{ri} = (0.150 \times 8) + 3.5ms$$

$$T_{ri1} = 4.7ms$$

$$T_{ri} = (0.150 \times 2) + 3.5ms$$

$$T_{ri2} = 3.8ms$$

4. There is one logical device for each 1771-ASB module. The largest block transfer for 1/4 logical racks is 64 words. Calculate the maximum length for these logical devices:

$$T_{ri} = 0.150 \times \text{block transfer length} + 3.5ms$$

$$T_{ri} = (0.150 \times 64) + 3.5ms$$

$$T_{ri3 \& 4} = 13.1ms$$

5. Add up all of the maximum word lengths:

$$T_{btx} = T_{ri1} + T_{ri2} + T_{ri3} + T_{ri4}$$

$$T_{btx} = 4.7 + 3.8 + 13.1 + 13.1$$

$$T_{btx} = 34.7ms$$

(1) This number is arbitrarily assigned.

6. Substitute all the values for variables in the throughput formula and solve for throughput:

$$T_{dm-bt} = T_{dm-nbt} + 2T_{btX}$$

$$T_{dm-bt} = 80ms + 2(34.7)ms$$

$$T_{dm-bt} = 149.4ms$$

Block Transfer Throughput

Block transfer throughput is *always* slower than discrete data transfer. It is dependent on the time involved for the:

- PLC control program to enable the block transfer⁽¹⁾
- PLC to generate a request for a block transfer⁽¹⁾
- 1747-ASB module to acknowledge the request⁽²⁾
- PLC to initiate the block transfer⁽¹⁾
- time involved to block transfer the data⁽³⁾
- 1747-ASB backplane scan⁽⁴⁾

As noted above, block transfer timing is PLC dependent. To calculate block transfer throughput, refer to the applicable PLC programming document.

(1) This is dependent on the PLC processor and scanner.

(2) Once the block transfer is request is received, the acknowledgement occurs in no more than one backplane scan and two RIO scans.

(3) The time involved to block transfer data is calculated using the T_{PI} formula in the previous section.

(4) The 1747-ASB backplane scan time is calculated in the same manner as described in the discrete throughput sections.

Differences Between the 1747-ASB Module and the 1771-ASB Series C Module

This appendix examines the differences between Catalog Number 1747-ASB and Catalog Number 1771-ASB Series C, Revision E or later. These differences are:

- image size selection
- hold last state operation
- specialty I/O module mapping and control
- remote expansion chassis
- starting logical group number selection
- inserting and removing I/O modules under power
- DIP switch locations
- I/O module keying
- physical slot numbering
- status indication
- throughput performance
- inhibit functionality

Page and chapter references are provided within each heading so you can quickly review the information specific to Catalog Number 1747-ASB.

The 1771-ASB image size is automatically selected based on the chassis size and addressing mode. The automatic assignment is possible because the number of 1771 chassis physical slots are provided in 2-group multiples. Therefore, there are no unused physical I/O slots or scanner image that is not utilized.

Image Size Selection (page 4-10)

The 1747-ASB image size must be selected with DIP switches (SW2-5,6,7,8). The selection is necessary because the 1746 chassis are not provided in 2-group multiples. In some cases, you must make a choice between not using a slot or not using scanner image. For more information on odd size chassis and image conditions, refer to page 4-13.

Hold Last State Operation (page 4-15)

When the hold last state mode is selected, the 1771-ASB module holds discrete outputs in their last state if:

- an error occurs
- RIO communications are lost
- the 1771-ASB module is inhibited
- the 1771-ASB module receives reset, adapter decide commands from the scanner

When the hold last state mode is selected the 1747-ASB module holds discrete outputs in their last state if:

- RIO communications are lost
- the 1747-ASB module is inhibited
- the 1771-ASB module receives reset, adapter decide commands from the scanner

The 1747-ASB module *always* clears discrete outputs if:

- an I/O module fault occurs
- a 1747-ASB error occurs
- a remote expansion chassis loses power

ATTENTION



When the discrete outputs are being held in their last state by the 1747-ASB module, the following information concerning the specialty modules must be considered:

The specialty I/O modules operate as if they are being controlled by an SLC processor in the run mode. Refer to the specialty I/O module's user manual to determine the response to this condition.

The specialty I/O modules inputs are read by the ASB module. However, the specialty I/O module's outputs are not modified by the ASB module.

Remote Expansion Chassis (page 3-1)

The 1771-ASB module does not support expansion chassis. It allows up to 16 physical slots in one 1771 chassis.

The 1747-ASB module can control up to three chassis; a remote chassis and two remote expansion chassis. If power to any remote expansion chassis is lost, a 1747-ASB error occurs and all discrete outputs are cleared, regardless of the hold last state switch setting. When power to the remote expansion chassis is restored, the ASB module automatically resumes operation as if the ASB module's power was cycled.

Inserting and Removing I/O Modules Under Power (page 6-9)

ATTENTION

Disconnect power to the 1771- or 1747-ASB chassis before attempting to insert, remove, or wire any I/O modules.

In most cases, inserting or removing I/O modules while under power does not cause a 1771-ASB error.

Whenever the 1747-ASB module is not faulted, inserting or removing I/O modules under power does cause a 1747-ASB error.

Starting Logical Group Number Selection (page 4-4)

In the RIO link system, only even numbered logical group numbers (0, 2, 4, or 6) are valid.

The 1771-ASB module limits the allowable starting logical group numbers based on the selected addressing mode and chassis size.

The 1747-ASB module allows virtually any group number to be selected. The exception is when 1/2-slot addressing and discrete mode is selected. Then, only logical groups 0 and 4 can be used.

Specialty I/O Module Image Mapping and Control (page 4-13)

The 1771-ASB module maps all discrete I/O modules using discrete transfers; data is exchanged with the scanner using RIO discrete transfers on the RIO link. All specialty (Intelligent)⁽¹⁾ I/O modules are block transfer mapped, data is exchanged with the scanner using RIO block transfers.

The 1747-ASB module handles discrete modules the same way the 1771-ASB module does by using RIO discrete transfers.

IMPORTANT

If you are only using discrete modules, the 1771-ASB and 1747-ASB modules mapping and control are identical.

(1) An Intelligent I/O module is a 1771 nondiscrete I/O module.

If the 1747-ASB module is configured for the block transfer mode, it handles all specialty I/O modules in the same manner as the 1771-ASB module does by using RIO block transfers.

IMPORTANT

PLC processor control of 1771 and 1747 specialty I/O modules on the RIO link is the same if the 1747-ASB module is configured for RIO block transfer. However, the I/O modules themselves are not controlled in the same way.

For example, if a 1771-IFE analog input module is used with the 1771-ASB module, RIO block transfers are used to transfer the 1771-IFE image data between the scanner and 1771-ASB module. In addition, the 1771-IFE module also receives configuration information from the scanner using RIO block transfers. If a 1746-NI4 analog input module is used with the 1747-ASB module, a RIO block transfer is used to transfer 1747-NI4 image data between the scanner and the 1747-ASB module. However the 1746-NI4 module requires no configuration information from the scanner.

In addition , the 1771-IFE image layout is not the same as the 1746-NI4 image layout. For example, the 1771-IFE image contains some alarm values and has words for the module's eight inputs. The 1746-NI4 image only has words for the module's four inputs.

If the 1747-ASB module is configured for the discrete mode, it attempts to map all specialty I/O modules discretely. For more information on how discrete I/O modules are mapped, refer to page 3-13.

DIP Switch Location (Chapter 4)

The 1771-ASB module has two DIP switches and uses one DIP switch on the 1771 chassis.

The 1747-ASB module has three DIP switches.

I/O Module Keying (page 4-21)

The 1771-ASB module uses the chassis hardware keying bands to ensure the proper I/O modules are installed in the correct slot.

The 1747-ASB module uses a DIP switch setting and software to ensure that the proper I/O modules are installed in the correct slots.

Physical Slot Numbering (page 3-2)

The 1771-ASB module resides in an unnumbered slot. The first physical slot available to an I/O module is slot 0. The subsequent *physical* slots are numbered decimally, up to a maximum of 15.

The 1747-ASB module resides in slot 0. The first physical slot available to an I/O module is slot 1. The subsequent physical slots are numbered decimally, up to a maximum of 30.

Status Indication (page 7-1)

The 1771-ASB module has three LEDs that indicate module and system status.

The 1747-ASB module has two LEDs and three 7-segment status display that indicate module and system status. The 7-segment status displays provide more detailed operating status and error indication than what can be provided with LEDs.

Throughput (page A-2)

In most cases the 1747-ASB throughput times are slower than the 1771-ASB throughput times. Refer to Appendix A for the 1747-ASB throughput time information.

Inhibit Functionality (page 6-3)

If some, but not all, of the 1771-ASB Series C, Revision E logical devices are inhibited, the 1771-ASB module continues to:

- communicate on the RIO link
- control outputs in its chassis

If some, but not all, of the 1747-ASB logical devices are inhibited, the 1747-ASB module:

- continues to communicate on the RIO link if processor restart lockout is *not selected*, or stops communicating on the RIO link if processor restart lockout is *selected*
- stops controlling outputs in its chassis regardless of the processor restart lockout selection. Outputs are held in last state if hold last state is selected or they are reset if hold last state is not selected.

DIP Switch and Address Configuration Worksheets

This appendix provides worksheets for you to configure your DIP switches and to address your I/O modules.

Use this worksheet to record the DIP switch settings for each of your module.

DIP Switch Configuration

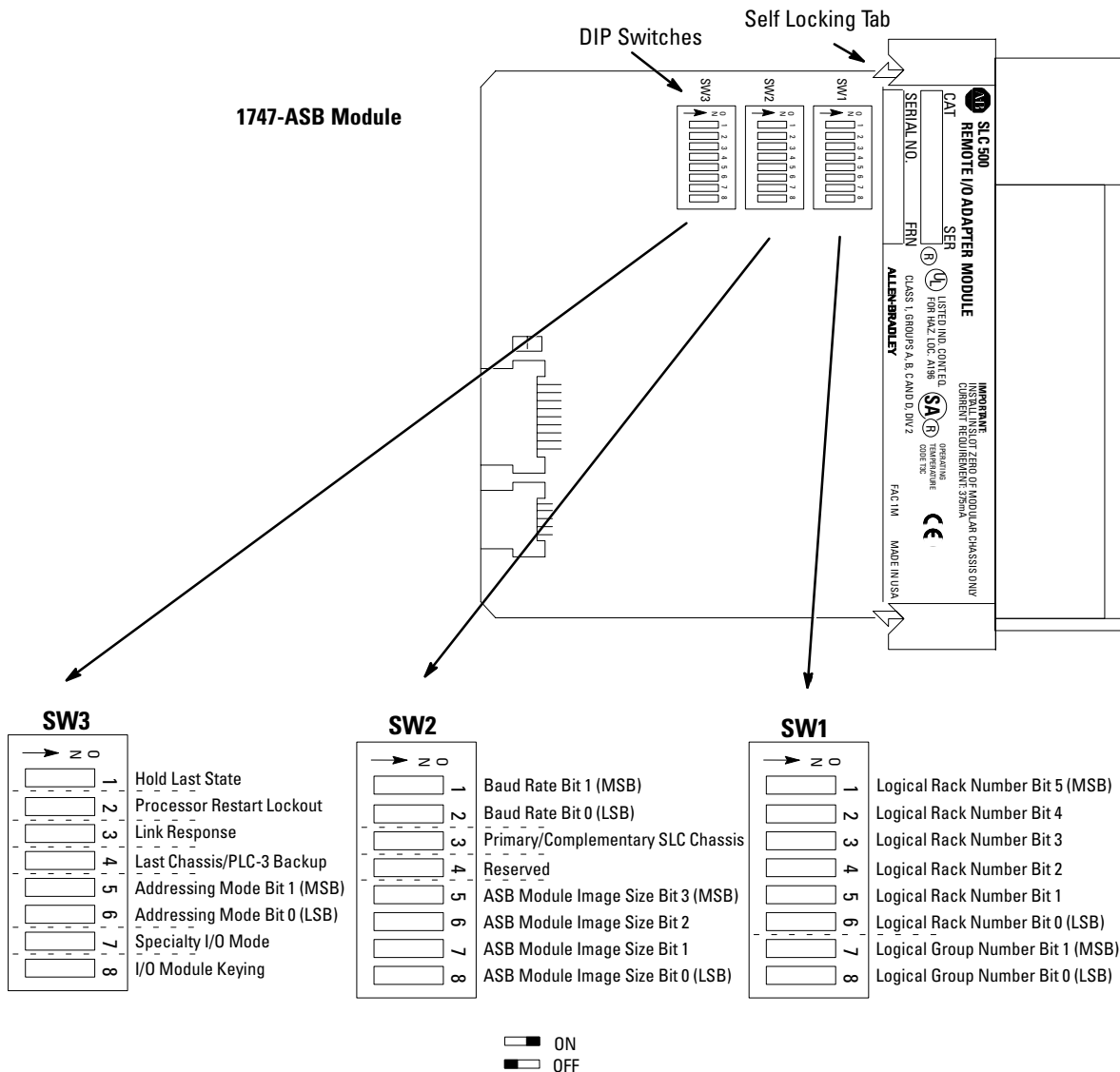

Module_	SW3		1 Hold Last State 2 Processor Restart Lockout 3 Link Response 4 Last Chassis/PLC-3 Backup 5 Addressing Mode Bit 1 (MSB) 6 Addressing Mode Bit 0 (LSB) 7 Specialty I/O Mode 8 I/O Module Keying	SW2		1 Baud Rate Bit 1 (MSB) 2 Baud Rate Bit 0 (LSB) 3 Primary/Complementary SLC Chassis 4 Reserved 5 ASB Module Image Size Bit 3 (MSB) 6 ASB Module Image Size Bit 2 7 ASB Module Image Size Bit 1 8 ASB Module Image Size Bit 0 (LSB)	SW1		1 Logical Rack Number Bit 5 (MSB) 2 Logical Rack Number Bit 4 3 Logical Rack Number Bit 3 4 Logical Rack Number Bit 2 5 Logical Rack Number Bit 1 6 Logical Rack Number Bit 0 (LSB) 7 Logical Group Number Bit 1 (MSB) 8 Logical Group Number Bit 0 (LSB)
	SW3		1 Hold Last State 2 Processor Restart Lockout 3 Link Response 4 Last Chassis/PLC-3 Backup 5 Addressing Mode Bit 1 (MSB) 6 Addressing Mode Bit 0 (LSB) 7 Specialty I/O Mode 8 I/O Module Keying	SW2		1 Baud Rate Bit 1 (MSB) 2 Baud Rate Bit 0 (LSB) 3 Primary/Complementary SLC Chassis 4 Reserved 5 ASB Module Image Size Bit 3 (MSB) 6 ASB Module Image Size Bit 2 7 ASB Module Image Size Bit 1 8 ASB Module Image Size Bit 0 (LSB)	SW1		1 Logical Rack Number Bit 5 (MSB) 2 Logical Rack Number Bit 4 3 Logical Rack Number Bit 3 4 Logical Rack Number Bit 2 5 Logical Rack Number Bit 1 6 Logical Rack Number Bit 0 (LSB) 7 Logical Group Number Bit 1 (MSB) 8 Logical Group Number Bit 0 (LSB)
	SW3		1 Hold Last State 2 Processor Restart Lockout 3 Link Response 4 Last Chassis/PLC-3 Backup 5 Addressing Mode Bit 1 (MSB) 6 Addressing Mode Bit 0 (LSB) 7 Specialty I/O Mode 8 I/O Module Keying	SW2		1 Baud Rate Bit 1 (MSB) 2 Baud Rate Bit 0 (LSB) 3 Primary/Complementary SLC Chassis 4 Reserved 5 ASB Module Image Size Bit 3 (MSB) 6 ASB Module Image Size Bit 2 7 ASB Module Image Size Bit 1 8 ASB Module Image Size Bit 0 (LSB)	SW1		1 Logical Rack Number Bit 5 (MSB) 2 Logical Rack Number Bit 4 3 Logical Rack Number Bit 3 4 Logical Rack Number Bit 2 5 Logical Rack Number Bit 1 6 Logical Rack Number Bit 0 (LSB) 7 Logical Group Number Bit 1 (MSB) 8 Logical Group Number Bit 0 (LSB)
	SW3		1 Hold Last State 2 Processor Restart Lockout 3 Link Response 4 Last Chassis/PLC-3 Backup 5 Addressing Mode Bit 1 (MSB) 6 Addressing Mode Bit 0 (LSB) 7 Specialty I/O Mode 8 I/O Module Keying	SW2		1 Baud Rate Bit 1 (MSB) 2 Baud Rate Bit 0 (LSB) 3 Primary/Complementary SLC Chassis 4 Reserved 5 ASB Module Image Size Bit 3 (MSB) 6 ASB Module Image Size Bit 2 7 ASB Module Image Size Bit 1 8 ASB Module Image Size Bit 0 (LSB)	SW1		1 Logical Rack Number Bit 5 (MSB) 2 Logical Rack Number Bit 4 3 Logical Rack Number Bit 3 4 Logical Rack Number Bit 2 5 Logical Rack Number Bit 1 6 Logical Rack Number Bit 0 (LSB) 7 Logical Group Number Bit 1 (MSB) 8 Logical Group Number Bit 0 (LSB)

Address Configuration

Use this worksheet to address the I/O modules residing in the 1747-ASB module chassis.

SLC Processor Input Image				SLC Processor Output Image				
Bit Number	Decimal	High Byte	Low Byte	Bit Number	Decimal	High Byte	Low Byte	
		15	8 7			0	15	8 7
Logical Rack 0	Group 0			I:e.0	Logical Rack 0	Group 0		O:e.0
	Group 1			I:e.1		Group 1		O:e.1
	Group 2			I:e.2		Group 2		O:e.2
	Group 3			I:e.3		Group 3		O:e.3
	Group 4			I:e.4		Group 4		O:e.4
	Group 5			I:e.5		Group 5		O:e.5
	Group 6			I:e.6		Group 6		O:e.6
	Group 7			I:e.7		Group 7		O:e.7
Logical Rack 1	Group 0			I:e.8	Logical Rack 1	Group 0		O:e.8
	Group 1			I:e.9		Group 1		O:e.9
	Group 2			I:e.10		Group 2		O:e.10
	Group 3			I:e.11		Group 3		O:e.11
	Group 4			I:e.12		Group 4		O:e.12
	Group 5			I:e.13		Group 5		O:e.13
	Group 6			I:e.14		Group 6		O:e.14
	Group 7			I:e.15		Group 7		O:e.15
Logical Rack 2	Group 0			I:e.16	Logical Rack 2	Group 0		O:e.16
	Group 1			I:e.17		Group 1		O:e.17
	Group 2			I:e.18		Group 2		O:e.18
	Group 3			I:e.19		Group 3		O:e.19
	Group 4			I:e.20		Group 4		O:e.20
	Group 5			I:e.21		Group 5		O:e.21
	Group 6			I:e.22		Group 6		O:e.22
	Group 7			I:e.23		Group 7		O:e.23
Logical Rack 3	Group 0			I:e.24	Logical Rack 3	Group 0		O:e.24
	Group 1			I:e.25		Group 1		O:e.25
	Group 2			I:e.26		Group 2		O:e.26
	Group 3			I:e.27		Group 3		O:e.27
	Group 4			I:e.28		Group 4		O:e.28
	Group 5			I:e.29		Group 5		O:e.29
	Group 6			I:e.30		Group 6		O:e.30
	Group 7			I:e.31		Group 7		O:e.31

e = Slot Number

SLC Processor Input Image

SLC Processor Output Image

Bit Number	Decimal	High Byte		Low Byte	Bit Number	Decimal	High Byte		Low Byte	
		15	8	7			0	15	8	7
Logical Rack 0	Group 0				I:e.0	Logical Rack 0	Group 0			O:e.0
	Group 1				I:e.1		Group 1			O:e.1
	Group 2				I:e.2		Group 2			O:e.2
	Group 3				I:e.3		Group 3			O:e.3
	Group 4				I:e.4		Group 4			O:e.4
	Group 5				I:e.5		Group 5			O:e.5
	Group 6				I:e.6		Group 6			O:e.6
	Group 7				I:e.7		Group 7			O:e.7
Logical Rack 1	Group 0				I:e.8	Logical Rack 1	Group 0			O:e.8
	Group 1				I:e.9		Group 1			O:e.9
	Group 2				I:e.10		Group 2			O:e.10
	Group 3				I:e.11		Group 3			O:e.11
	Group 4				I:e.12		Group 4			O:e.12
	Group 5				I:e.13		Group 5			O:e.13
	Group 6				I:e.14		Group 6			O:e.14
	Group 7				I:e.15		Group 7			O:e.15
Logical Rack 2	Group 0				I:e.16	Logical Rack 2	Group 0			O:e.16
	Group 1				I:e.17		Group 1			O:e.17
	Group 2				I:e.18		Group 2			O:e.18
	Group 3				I:e.19		Group 3			O:e.19
	Group 4				I:e.20		Group 4			O:e.20
	Group 5				I:e.21		Group 5			O:e.21
	Group 6				I:e.22		Group 6			O:e.22
	Group 7				I:e.23		Group 7			O:e.23
Logical Rack 3	Group 0				I:e.24	Logical Rack 3	Group 0			O:e.24
	Group 1				I:e.25		Group 1			O:e.25
	Group 2				I:e.26		Group 2			O:e.26
	Group 3				I:e.27		Group 3			O:e.27
	Group 4				I:e.28		Group 4			O:e.28
	Group 5				I:e.29		Group 5			O:e.29
	Group 6				I:e.30		Group 6			O:e.30
	Group 7				I:e.31		Group 7			O:e.31

e = Slot Number

Numerics

1/2-slot addressing 3-10

- considerations 3-11
- examples 3-12

1771-ASB series c B-1

1-slot addressing

- considerations 3-8
- examples 3-9

2-slot addressing 3-4

- considerations 3-5
- examples 3-6

A

adapter 1-4

- extended node capability 1-8
- interaction with scanners 1-2
- on RIO link as slave device 1-2

adapter image 1-4

- in relation to logical devices 1-6
- size of 1-5

addressing I/O modules 3-3

- 1/2-slot addressing 3-10
 - considerations 3-11
 - examples 3-12
- 1-slot addressing 3-7, 3-8
 - considerations 3-8
 - examples 3-9
- 2-slot addressing 3-4
 - considerations 3-5
 - examples 3-6

- configuration worksheet C-3
- overview 3-3

addressing labels

- attaching to the I/O modules 2-5, 5-6

addressing mode 4-21

- in basic SLC example 8-3, 8-4
- in PLC example 8-17, 8-18, 8-21, 8-22
- in SLC example 8-9, 8-12, 8-13

Allen-Bradley 7-2

- contacting for assistance 7-2

application example program 8-7

- basic SLC 8-7
- PLC 8-24
- SLC 8-15

application examples 8-1

- basic SLC 8-1
- PLC 8-15
- SLC 8-7

ASB module backplane scan time

- throughput A-6

ASB module features 1-10

- hardware 1-11
 - cable tie slots 1-13
 - DIP switches 1-11
 - door label 1-13
 - RIO link and processor restart lock-out 1-13
 - self-locking tabs 1-13
 - status display and LEDs 1-11

ASB module image size 4-10

- special image and chassis size considerations 4-13

ASB module installation 5-1

B

base backplane scan time

- throughput A-6

basic SLC application example 8-1

- application example program 8-7
- ASB module I/O mapping details 8-4
- module configuration details 8-4
- processor image 8-3
- RIO address label example 8-5
- RIO device configuration 8-3

baud rate 1-12

- ASB module feature 1-10
- DIP switch setting 4-4
- link termination 5-4
- link wiring 5-2
- PLC example 8-17
- SLC basic example 8-2
- SLC example 8-9

block transfer 1-7

- throughput A-12
- transferring data 1-7

block transfer mode 3-14

C

cable distances 5-2

- maximum 5-2

cable tie slots 1-13

chassis overview 3-1, 4-13

- odd sizes 4-13
- remote chassis 3-1
- remote expansion chassis 3-1
- types available 3-1

check mode 6-2

Class1, Division 2 5-5

- momentary switch 5-5

compatible modules 1-10
compatible RIO adapters 1-9
compatible RIO scanners 1-8
complementary I/O 4-5
 in basic SLC application example 8-3, 8-4
 in PLC application example 8-17, 8-19, 8-20
 in SLC application example 8-9, 8-11
contacting Allen-Bradley for assistance 7-2

D

definitions 1-3
differences between 1747-ASB and 1771-ASB series c modules B-1
 DIP switch locations B-4
 hold last state B-2
 I/O module keying B-4
 image size selection B-1
 inhibit functionality B-5
 inserting and removing I/O modules under power B-3
 physical slot numbering B-5
 remote expansion chassis B-2
 specialty I/O module image mapping and control B-3
 starting logical group number selection B-3
 status indication B-5
 throughput B-5
DIP switch 4-1
 configuration of mismatch fault codes 7-5
 configuration worksheet C-1
 summary of switch settings 4-22
 SW 2 4-4
 configuration 4-4, 4-6
 SW 3 4-15
 configuration 4-15
DIP switch configuration mismatch fault codes 7-5
discrete I/O modules 3-13
 mapping 3-13
 overview of 3-13
discrete I/O throughput with block transfers present example A-10
discrete I/O throughput without block transfers present example A-7
discrete mode 3-15
discrete transfer 1-2
 transferring data 1-6

door labels 1-13
 applying octal labels 2-6

E

equipment needed 2-1
errors 7-1
 major 7-1
 minor 7-1
examples 8-1
 basic SLC application 8-1
 SLC application 8-7
extended node capability 1-8
 link termination 5-4
 of scanners and adapters 1-8
 of the ASB module 1-8

H

hardware features 1-11
 cable tie slots 1-13
 DIP switches 1-11
 door label 1-13
 RIO link and processor restart lockout connector 1-13
 self-locking tabs 1-13
 status displays and LEDs 1-11
hold last state 4-15
 in basic SLC example 8-3, 8-4
 in PLC example 8-17, 8-19, 8-20
 in SLC example 8-9, 8-11
 start up and operation 6-5
humidity specifications A-1

I

I/O module addressing labels 5-6
 PLC as master 5-6
 SLC as master 5-6
I/O module configuration mismatch fault codes 7-7
I/O module insertion under power 6-9
I/O module keying 4-22
 in basic SLC example 8-3
 in SLC example 8-9
I/O module removal from a scanned slot 6-9
I/O module removal from an unscanned slot 6-10
I/O runtime fault codes 7-8
image mapping 3-13
 discrete 3-13
 specialty 3-13

inhibit 6-4
installing the ASB module in an SLC chassis 5-1
invalid RIO link transfers 6-6

L

labels, addressing
 attaching to the I/O modules 2-5, 5-6
labels, door 1-13
 applying octal labels 2-6
last chassis/PLC 3 backup 4-19
 in basic SLC example 8-3, 8-4
 in PLC example 8-17, 8-19, 8-20
 in SLC example 8-9, 8-11
link response time 4-18
 in basic SLC example 8-3
 in PLC example 8-17, 8-19, 8-20
 in SLC example 8-9
link termination 5-4
 resistor required for 5-4
link wiring 5-2
 correct link wiring 5-2
 incorrect link wiring 5-2
 link termination 5-4
logical device 1-6
 adapters 1-6
 assigning space C-3
logical group 1-4
logical rack 1-4
 crossing logical rack boundaries 1-5
 significance of 1-6

M

major error 7-1
manuals
 related 1-2
master device 1-2
minor error 7-1

N

network specifications A-1
normal operation 6-2
 exceptions 6-3
 status display codes 7-2

O

octal labeling information
 image bit numbering 1-5
operation 6-2
 exceptions 6-3

status display codes for normal operating conditions 7-2

P

PLC application example 8-15
 application example program 8-24
 ASB module 1 configuration 8-19
 ASB module 1 I/O mapping 8-21
 ASB module 2 configuration 8-20
 ASB module 2 I/O mapping 8-22
 PLC processor image 8-18
 RIO address label examples 8-23
 RIO device configuration 8-17
power supply loading specification A-1
power up and initialization 6-1
 check mode 6-2
 save mode 6-2
processor restart lockout 4-17
 in basic SLC example 8-3, 8-4
 in PLC example 8-17, 8-19, 8-20
 in SLC example 8-9, 8-11
 not selecting 6-4
 selecting 6-4
 switch wiring 5-5
publications
 related 1-2

R

rack boundaries
 crossing logical 1-5
remote chassis 3-1
 slot numbering 3-2
 with I/O modules 1-1
 with remote I/O 1-2
remote expansion chassis 3-1
 slot numbering 3-2
 with I/O modules 1-1
 with remote I/O 1-2
remote expansion chassis power loss 6-6
remote I/O overview 1-2
required tools and equipment 2-1
reset, adapter decide 6-3
 status display codes 7-2
reset, adapter reset 6-3
 status display codes 7-2
RIO
 compatible adapters 1-9
 compatible scanners 1-8
RIO adapters 5-6
RIO address label 8-5

- basic SLC application example 8-5
- PLC application example 8-23
- PLC example 5-6
- SLC application example 8-13
- SLC example 5-6

RIO device configuration 8-17

- basic SLC application example 8-2
- PLC application example 8-17
- SLC application example 8-9

RIO link 1-2

- invalid link transfers 6-6
- physical and logical specifications 1-8

RIO scan time

- throughput A-5

S**save mode** 6-2**scanner** 1-2

- extended node capability 1-8
- image division 1-4
 - logical groups 1-4
 - logical racks 1-4
- interaction with adapters 1-2
- overview 1-2

slave device 1-2**SLC application example** 8-7

- application example program 8-15
- ASB module 1 configuration 8-10
- ASB module 1 I/O mapping 8-12
- ASB module 2 configuration 8-11
- ASB module 2 I/O mapping 8-13
- processor image 8-10
- RIO address label examples 8-13
- RIO device configuration 8-9

slot numbering 3-2

- ASB module placement 3-2

slot pairing 8-12**specialty I/O mode** 4-21

- in PLC example 8-17, 8-21
- in SLC basic example 8-3
- in SLC example 8-9, 8-12, 8-13

specialty I/O modules 3-14

- mapping 3-14
 - block transfer mode 3-15
 - discrete mode 3-16
- overview 3-13

specifications A-1

- network specifications A-1
- power supply loading A-1
- temperature and humidity A-1
- throughput A-1

start up and operation 6-1**status display codes** 7-2

- DIP switch configuration mismatch fault codes 7-5
- I/O module configuration mismatch fault codes 7-7
- I/O runtime fault codes 7-8
- status operating codes for normal operating conditions 7-2

status operating codes for normal operating conditions 7-2**SW 2** 4-4

- DIP switch 4-4

SW 3 4-15

- DIP switch 4-15
 - addressing mode 4-21
 - hold last state 4-15
 - I/O module keying 4-22
 - last chassis/PLC 3 backup 4-19
 - link response time 4-18
 - power up and initialization 6-1
 - processor restart lockout 4-17
 - specialty I/O mode 4-21
 - system startup 6-1

system start up 6-1**T****temperature specifications** A-1**terms** 1-3**testing the ASB module** 6-7**throughput** A-2

- calculating throughput A-4
 - block transfer A-12
 - with block transfers present A-9
 - without block transfers present A-4
- introduction A-2

tools needed 2-1**transferring data with RIO discrete and block transfers** 1-7

- overview 1-7
- RIO discrete example 1-7

troubleshooting 7-1

- contacting Allen-Bradley 7-2
- major error 7-1
- minor error 7-1

W**wiring a processor restart lockout switch** 5-5

- status display code 7-2

www.rockwellautomation.com

Power, Control and Information Solutions Headquarters

Americas: Rockwell Automation, 1201 South Second Street, Milwaukee, WI 53204-2496 USA, Tel: (1) 414.382.2000, Fax: (1) 414.382.4444

Europe/Middle East/Africa: Rockwell Automation, Vorstlaan/Boulevard du Souverain 36, 1170 Brussels, Belgium, Tel: (32) 2 663 0600, Fax: (32) 2 663 0640

Asia Pacific: Rockwell Automation, Level 14, Core F, Cyberport 3, 100 Cyberport Road, Hong Kong, Tel: (852) 2887 4788, Fax: (852) 2508 1846

Publication 1747-UM006B-EN-P - June 2003

Supersedes Publication 1747-6.13 - December 1996

Copyright © 2003 Rockwell Automation. All rights reserved. Printed in the U.S.A.